

\varnothing_1 [mm]	Numer chwytu	∇	\varnothing_2 [mm]	l [mm]	l [mm] dla elektrod odsadzonych	\varnothing_3 [mm]	SW	Katalog produktów
13	11	MK1	12,065	14	20	8,0	11	STOŻEK NR 11
18	21	MK2	17,781	20	25	9,5	17	STOŻEK NR 21
18	22	MK2	16	20	25	9,0	17	
	23	MK3	23,825	30		12,5		
13	31	BS	10,8	10	12	7,0	11	STOŻEK NR 31
14	32	BS	12,7	13	16	8,0	13	STOŻEK NR 32
16 (18)	33	BS	14,8	15	20	9,0	13	STOŻEK NR 33
20	34	BS	19,05	20	20	11,0	17	STOŻEK NR 34
20	35	BS	18	20	25	9,5	17	
18	36	BS	16	16	20			
14 (16)	40	01:10	12	8 (15)	15	7,5	14	STOŻEK NR 40
13	41	01:10	9,8	13	13	6,0	11	
13 (14)	42	01:10	10,5	12	12	6,5	11	STOŻEK NR 42
13	43	01:10	11,8	14	20	7,5	11	
14	44	01:10	12,7	16	20	8,0	13	STOŻEK NR 44
16	45	01:10	15,5	20	32	9,0	13	STOŻEK NR 45
18	46	01:10	17,8	20	25	9,5	17	
20	47	01:10	19	25	30	11,0	17	STOŻEK NR 47
	48	01:10	18	20				
	51	DIN13	10	6,5	6,5			
	52	DIN16	12	8	8			
	53	DIN20	15	10	10			

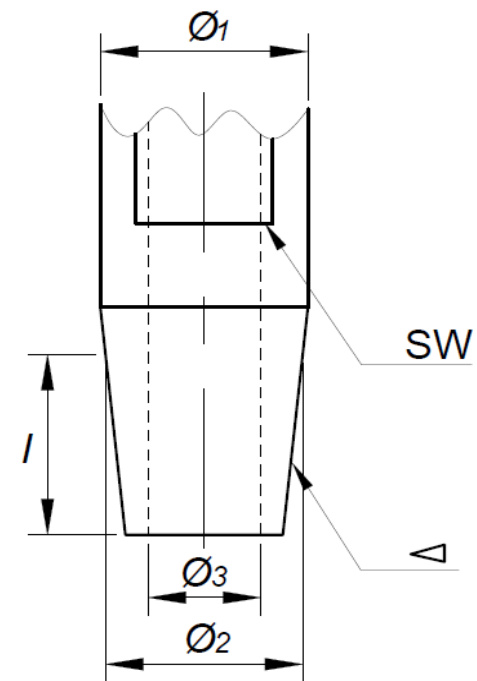

Chwyt elektrod - wymiary