

KATALOG ELEKTROD DO ZGRZEWANIA REZYSTANCYJNEGO

STOŻEK NR 32

zbieżność BS $\varnothing 12,7$



KARTY KATALOGOWE

PRODUKTY

01.....	ELEKTRODY PROSTE
02.....	ELEKTRODY ODSADZONE KUTE
03.....	ELEKTRODY ODSADZONE GIĘTE
04.....	ELEKTRODY ODSADZONE PODWÓJNIE GIĘTE
05.....	ELEKTRODY PŁASKIE
06.....	OBSADY ELEKTROD NASADKOWYCH
07.....	OBSADY ELEKTROD GRZYBKOWYCH I WKRETEK ELEKTRODOWYCH
08.....	ELEKTRODY DO ZGRZEWANIA ŚRUB I NAKRĘTEK
09.....	ELEKTRODY WOLFRAMOWE
10.....	ŚWIECE ELEKTRODOWE
11.....	ELEKTRODY KRAŻKOWE
12.....	MATERIAŁY, OSPRZĘT, URZĄDZENIA DO ZGRZEWAREK

ASweld

ELEKTRODY PROSTE

STOŻEK NR 32

zbieżność BS $\varnothing 12,7$

Karty katalogowe: 01-__-__-32



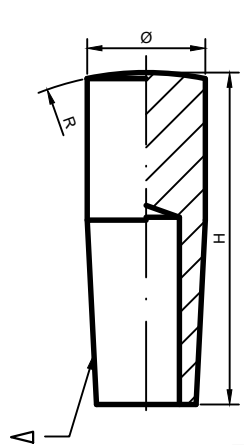

AW: A(R)-Ø.H-Δ

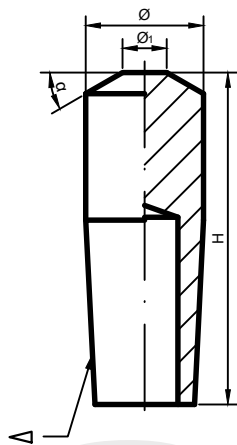

AW: Bk(Ø1)-Ø.H-Δ

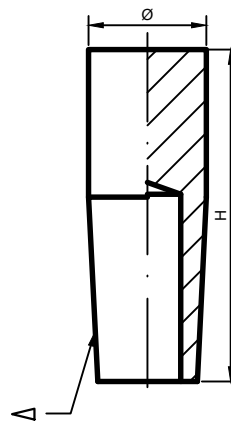

AW: C-Ø.H-Δ

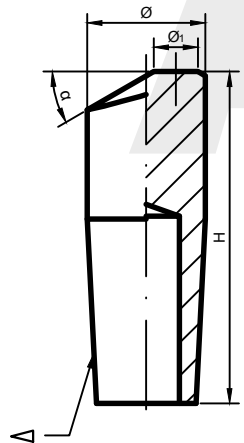

AW: Dk(Ø1)-Ø.H-Δ

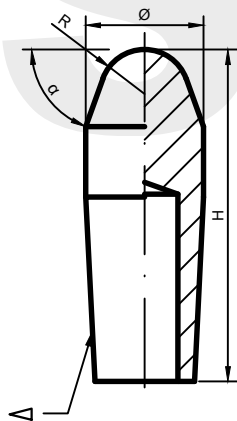

AW: Ek(R)-Ø.H-Δ

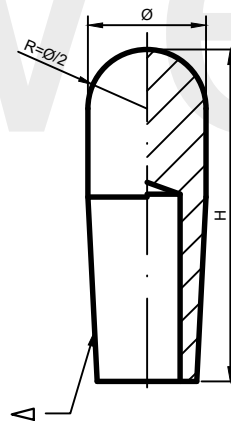

AW: F-Ø.H-Δ

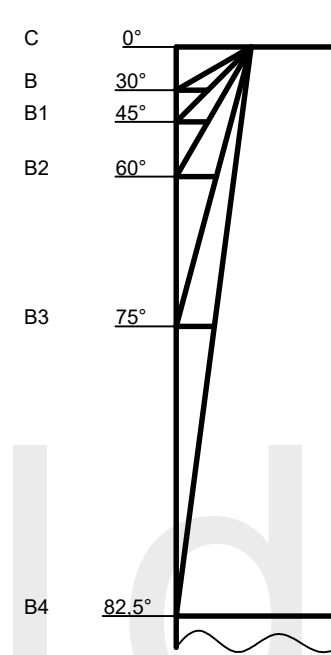

k	α
-	30°
1	45°
2	60°
3	75°
4	82,5°



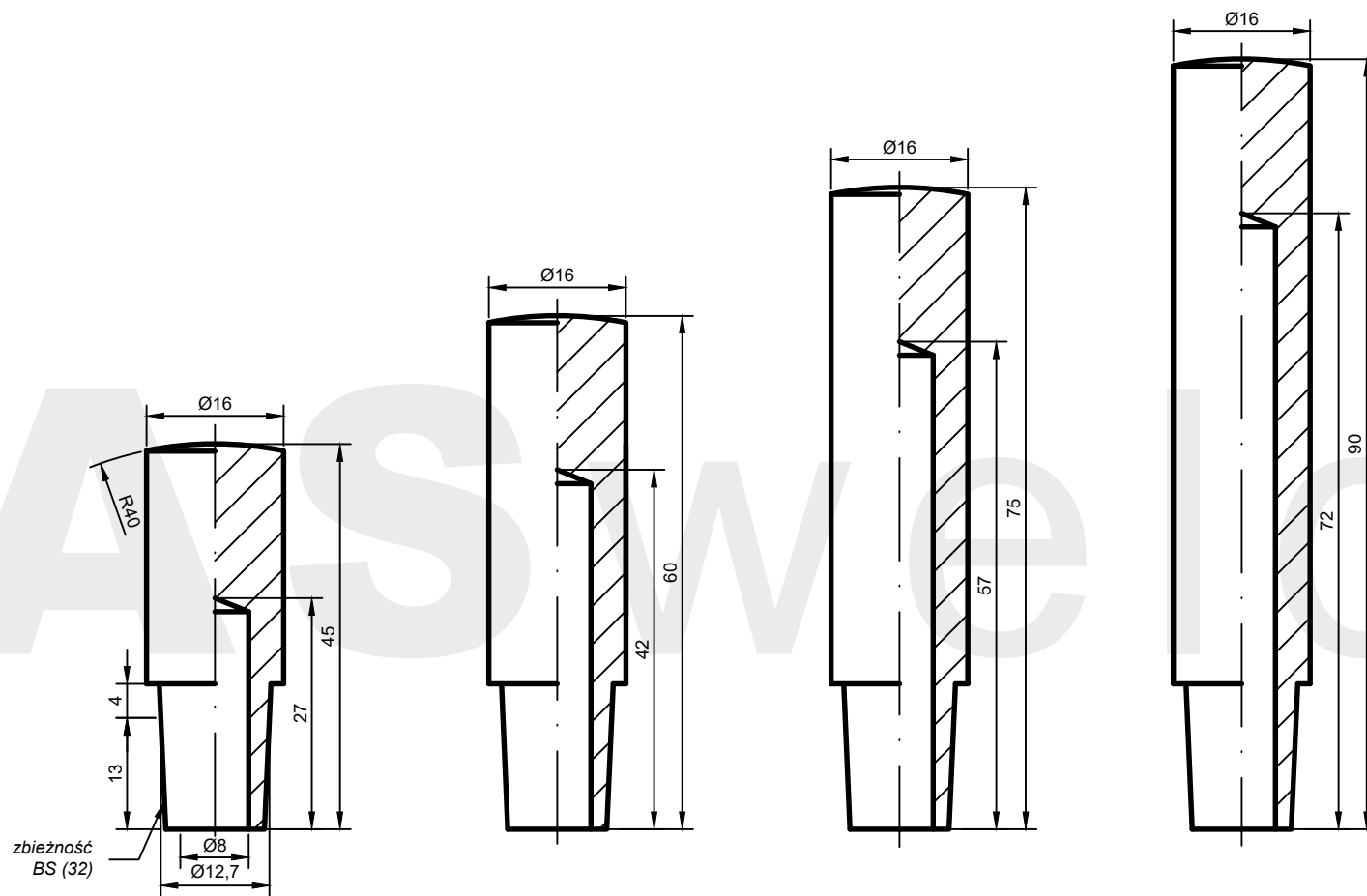

AW: A(40)-16.45-32

AW: A(40)-16.60-32*

AW: A(40)-16.75-32*

AW: A(40)-16.90-32*

*wykonanie na zamówienie

ASweld

ELEKTRODA PROSTA
forma A

Chwyt elektrody

32

Karta katalogowa

01-01-01-32

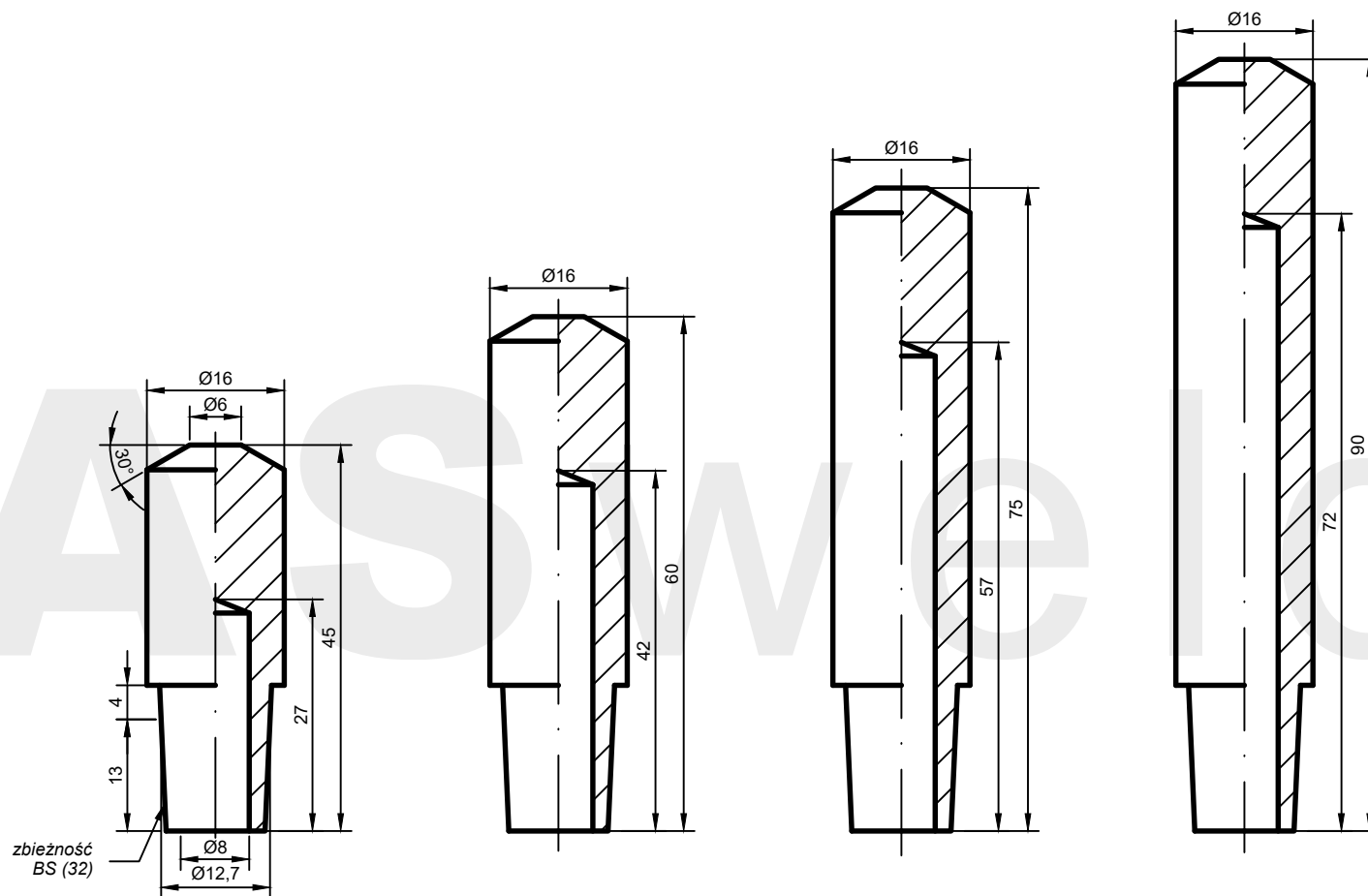

AW: B(6)-16.45-32*

AW: B(6)-16.60-32

AW: B(6)-16.75-32*

AW: B(6)-16.90-32*

*wykonanie na zamówienie

ASweld

ELEKTRODA PROSTA
forma B

Chwyt elektrody

32

Karta katalogowa

01-02-01-32

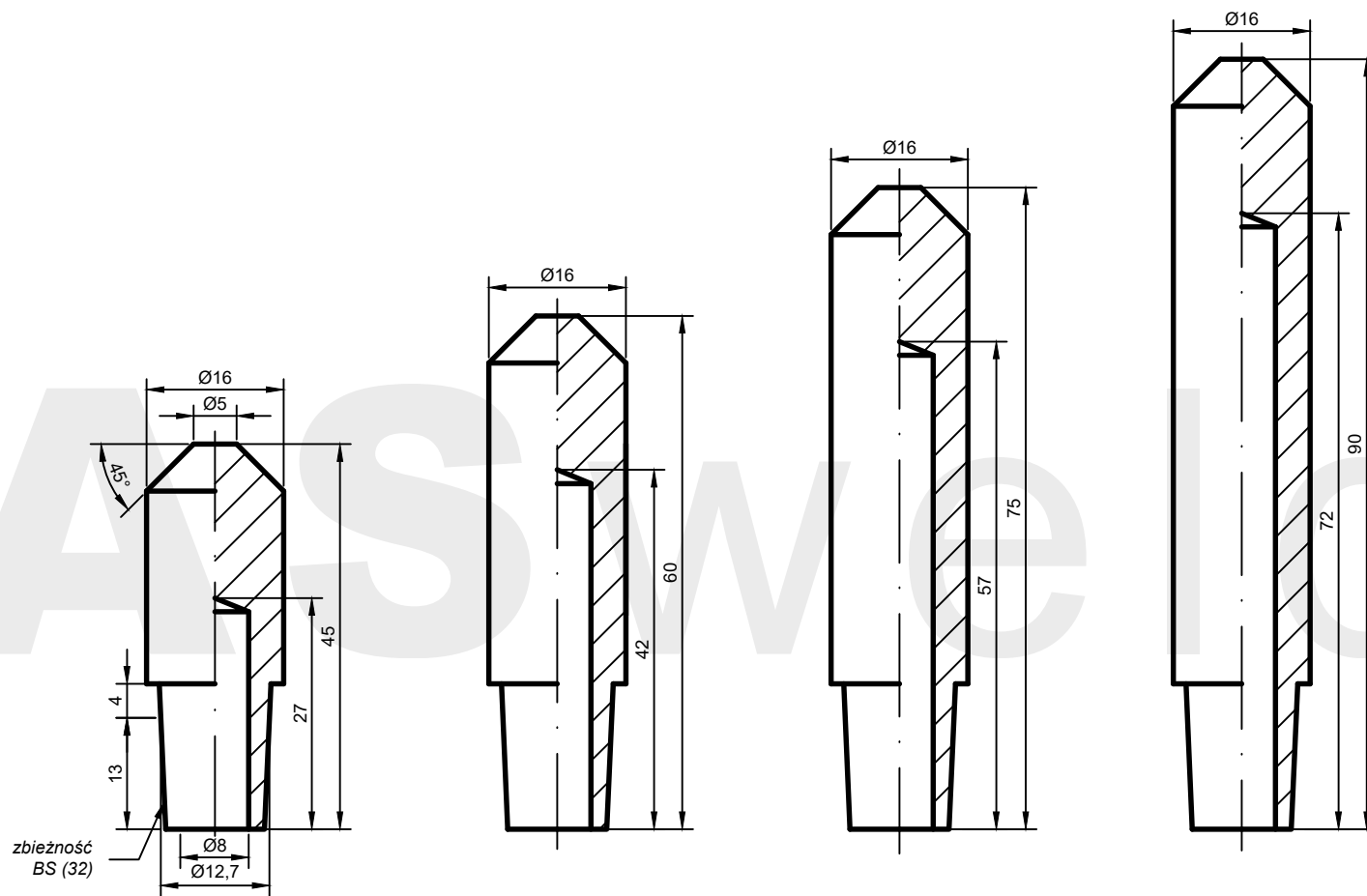

AW: B1(5)-16.45-32*

AW: B1(5)-16.60-32

AW: B1(5)-16.75-32*

AW: B1(5)-16.90-32*

*wykonanie na zamówienie

ASweld

ELEKTRODA PROSTA
forma B1

Chwył elektrody

32

Karta katalogowa

01-02-02-32

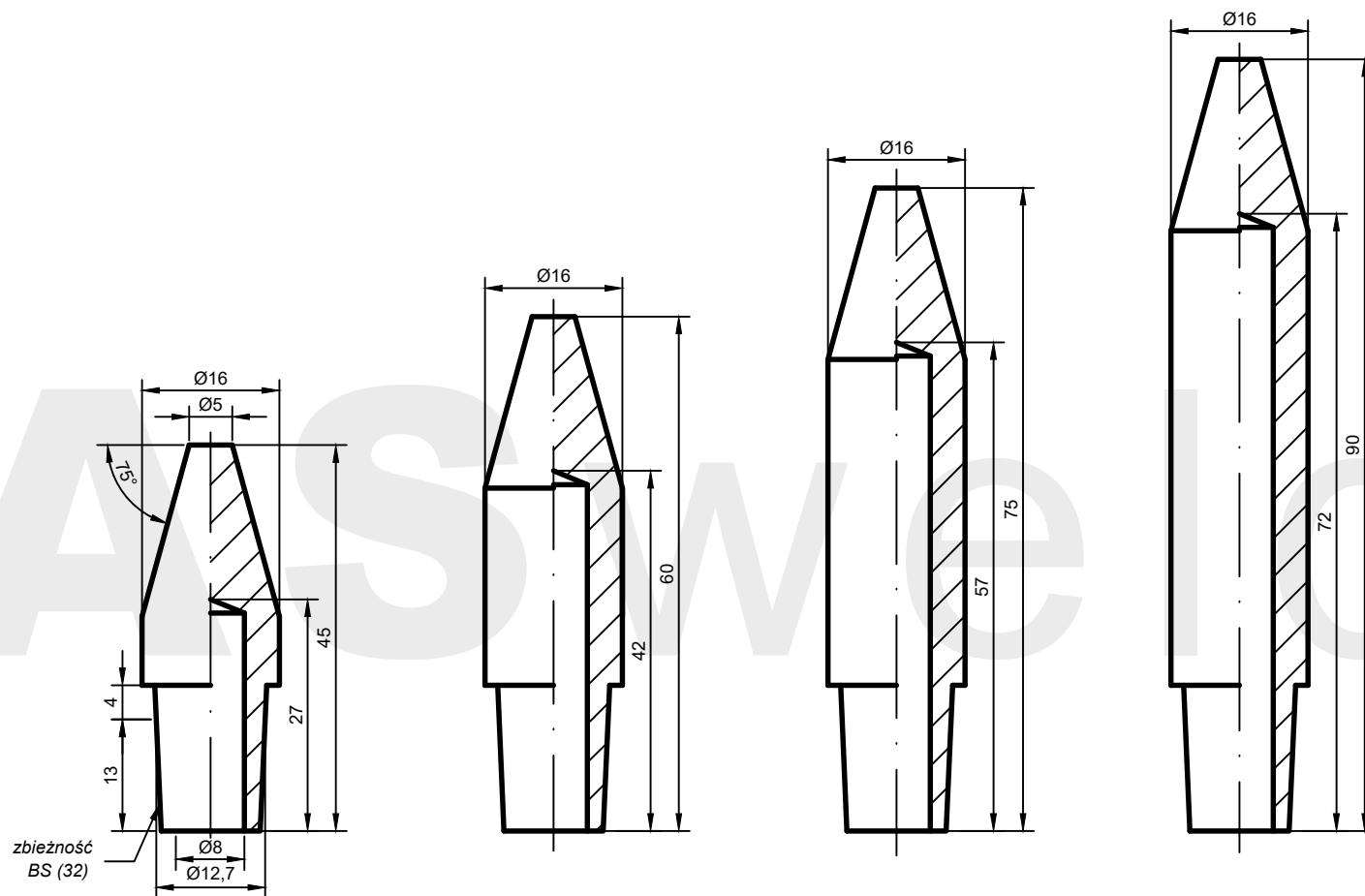

AW: B3(5)-16.45-32*

AW: B3(5)-16.60-32

AW: B3(5)-16.75-32*

AW: B3(5)-16.90-32*

*wykonanie na zamówienie

ASweld

ELEKTRODA PROSTA
forma B3

Chwyt elektrody

32

Karta katalogowa

01-02-03-32

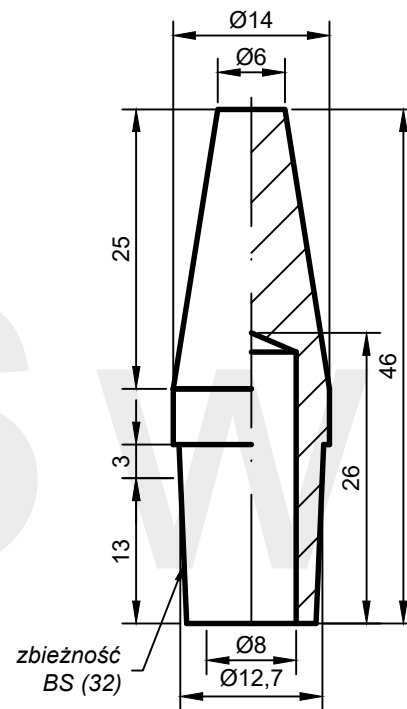

AW: B4(6)-14.46-32

*wykonanie na zamówienie

ASweld

ELEKTRODA PROSTA
forma B4

Chwył elektrody

32

Karta katalogowa

01-02-04-32

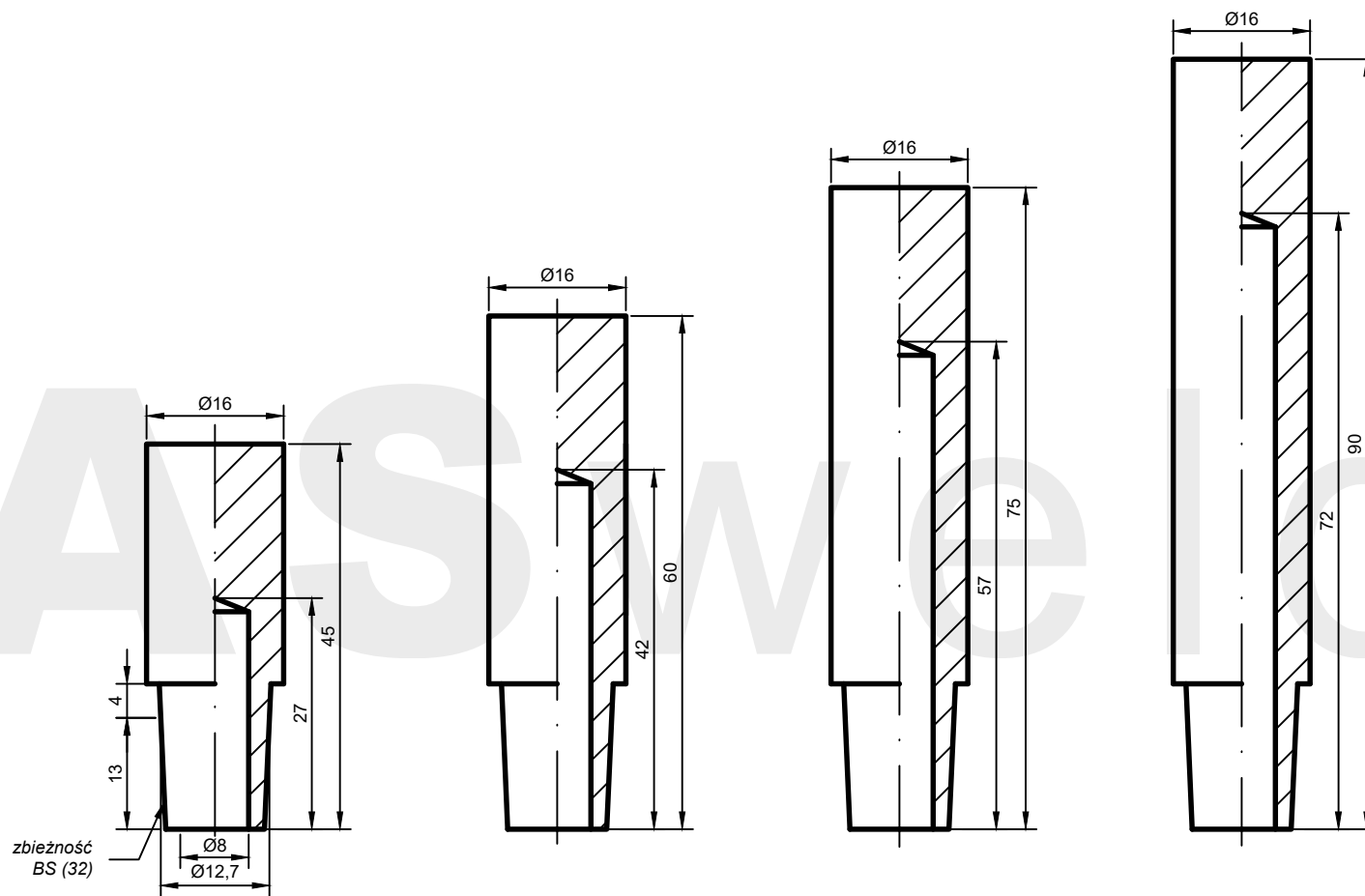

AW: C-16.45-32*

AW: C-16.60-32

AW: C-16.75-32*

AW: C-16.90-32*

*wykonanie na zamówienie

ASweld

ELEKTRODA PROSTA
forma C

Chwyt elektrody

32

Karta katalogowa

01-03-01-32

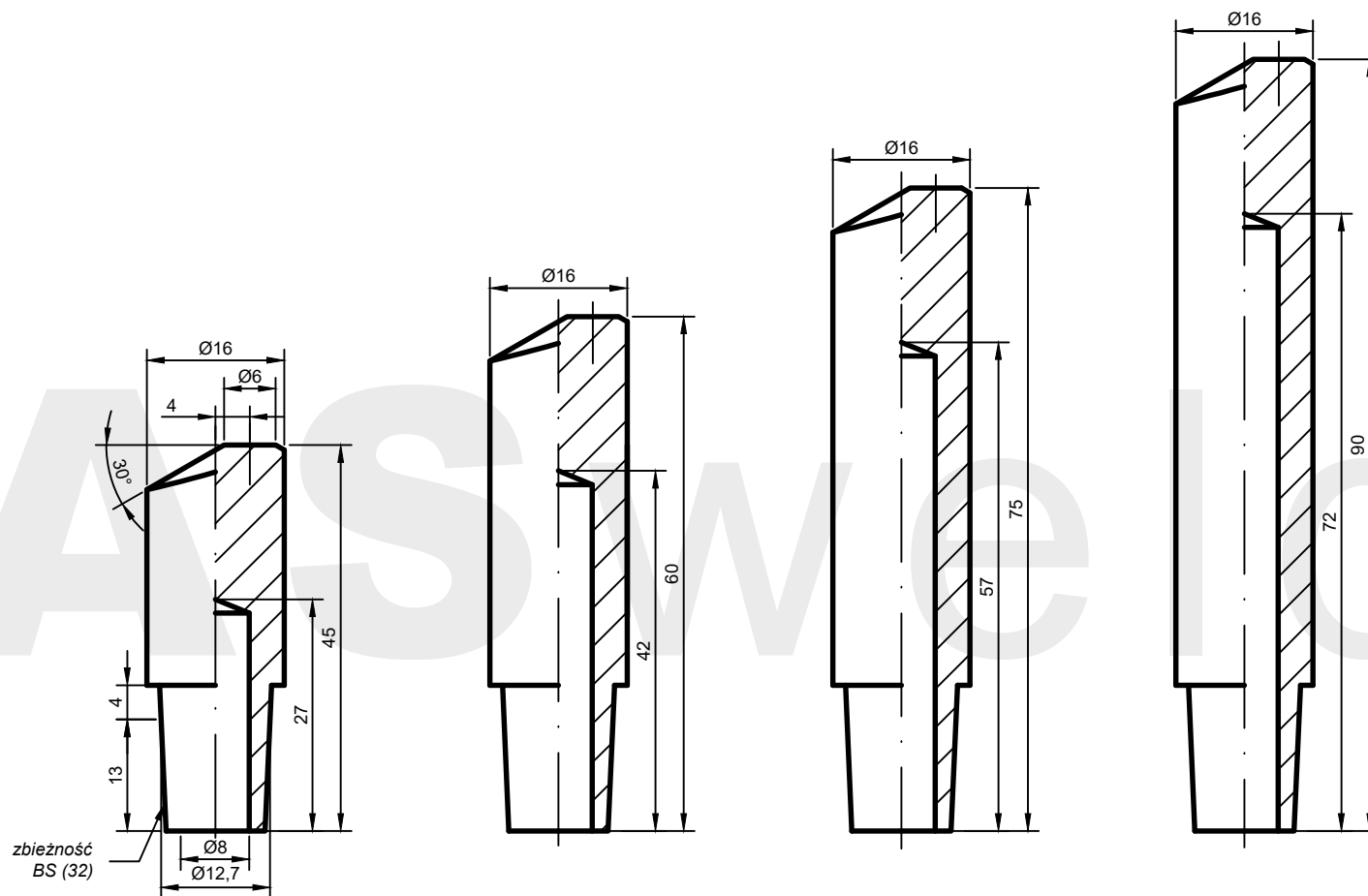

AW: D(6)-16.45-32*

AW: D(6)-16.60-32

AW: D(6)-16.75-32*

AW: D(6)-16.90-32*

*wykonanie na zamówienie

ASweld

ELEKTRODA PROSTA
forma D

Chwył elektrody

32

Karta katalogowa

01-04-01-32

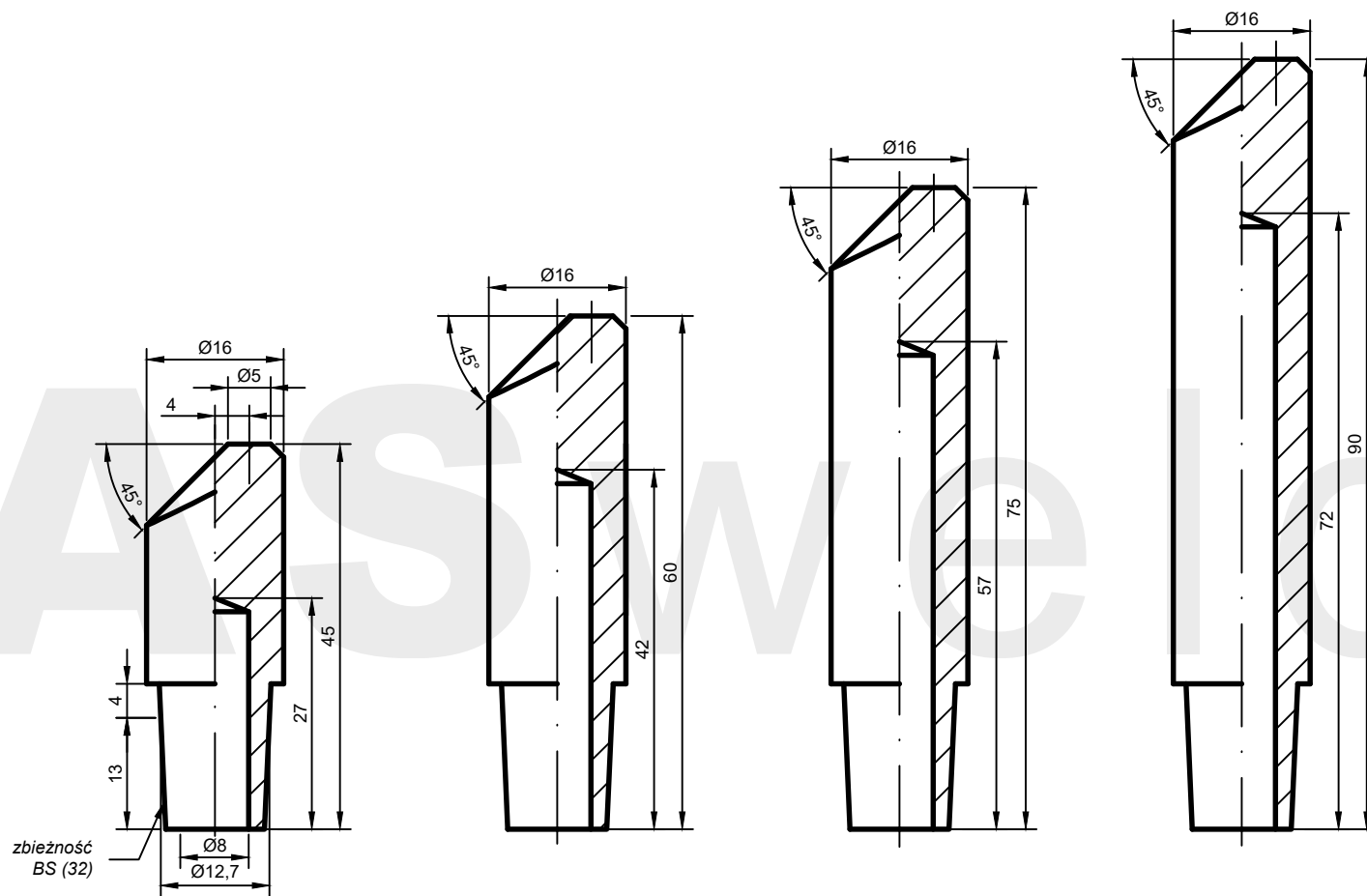

AW: D1(5)-16.45-32*

AW: D1(5)-16.60-32

AW: D1(5)-16.75-32*

AW: D1(5)-16.90-32*

*wykonanie na zamówienie

ASweld

ELEKTRODA PROSTA
forma D1

Chwył elektrody

32

Karta katalogowa

01-04-02-32

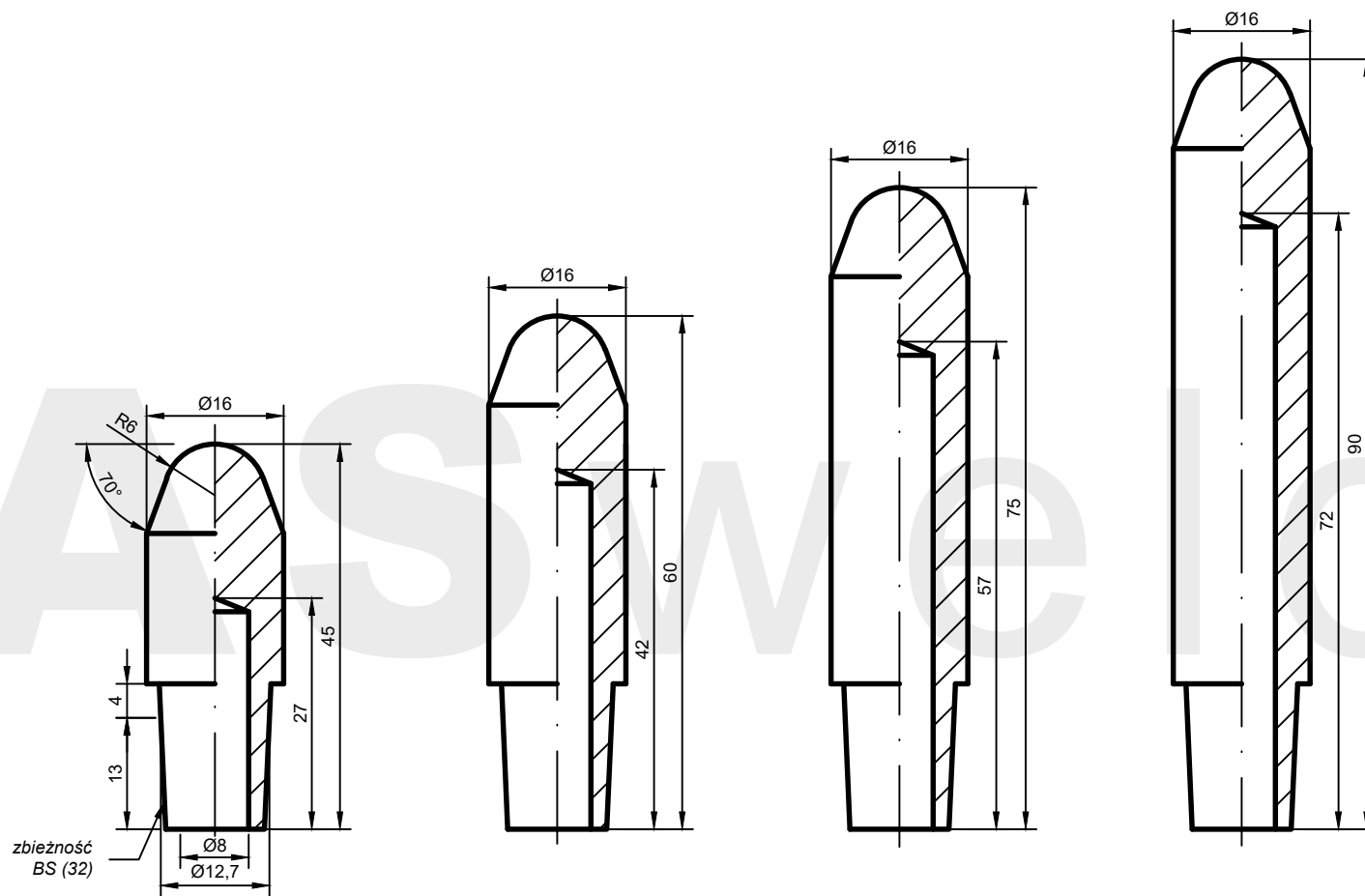

AW: E(6)-16.45-32*

AW: E(6)-16.60-32

AW: E(6)-16.75-32*

AW: E(6)-16.90-32*

*wykonanie na zamówienie

ASweld

ELEKTRODA PROSTA
forma E

Chwył elektrody

32

Karta katalogowa

01-05-01-32

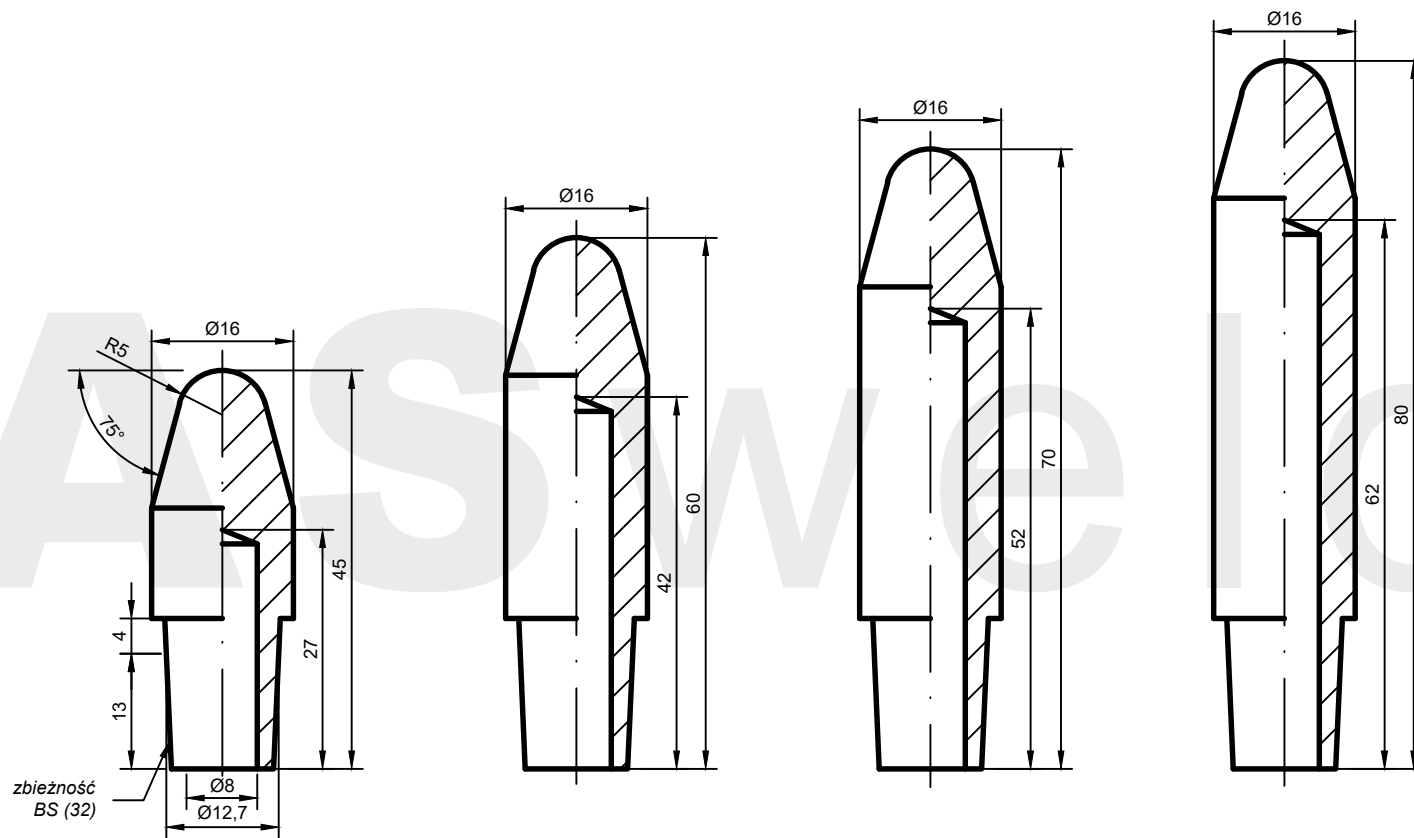

AW: E3(5)-16.45-32*

AW: E3(5)-16.60-32

AW: E3(5)-16.70-32*

AW: E3(5)-16.80-32*

*wykonanie na zamówienie

ASweld

ELEKTRODA PROSTA
forma E3

Chwył elektrody

32

Karta katalogowa

01-05-02-32

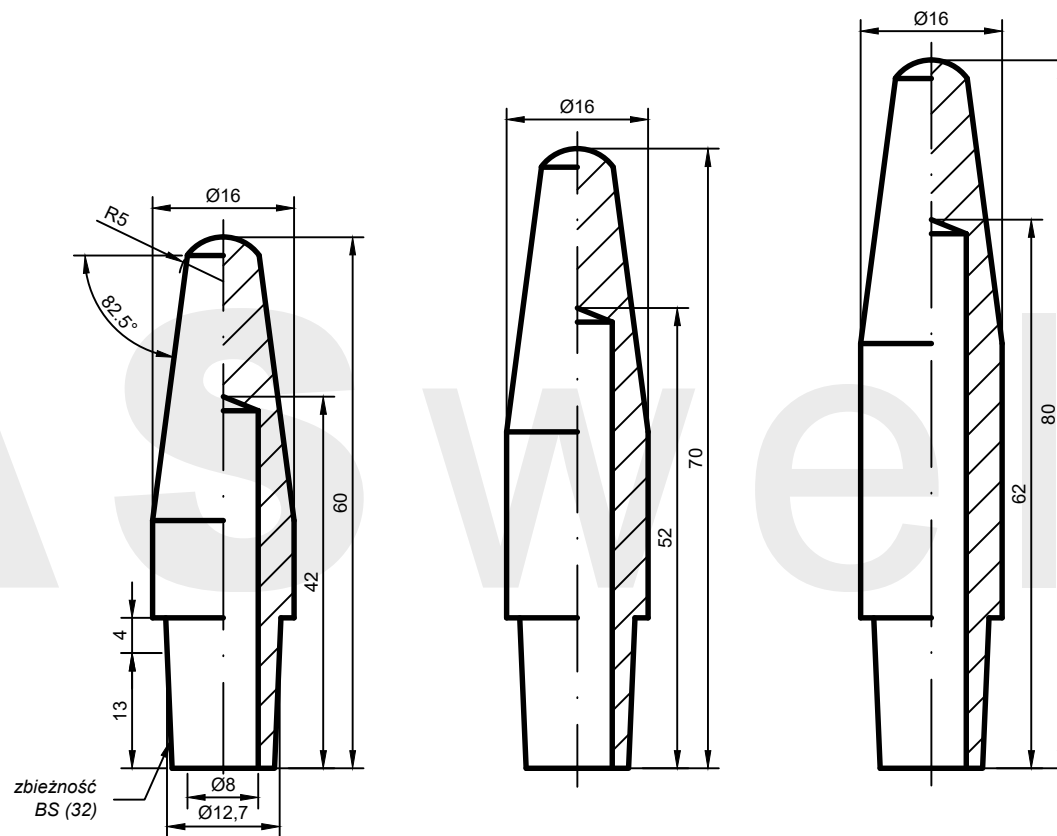

AW: E4(5)-16.60-32

AW: E4(5)-16.70-32*

AW: E4(5)-16.80-32*

*wykonanie na zamówienie

ASweld

ELEKTRODA PROSTA
forma E4

Chwył elektrody

32

Karta katalogowa

01-05-03-32

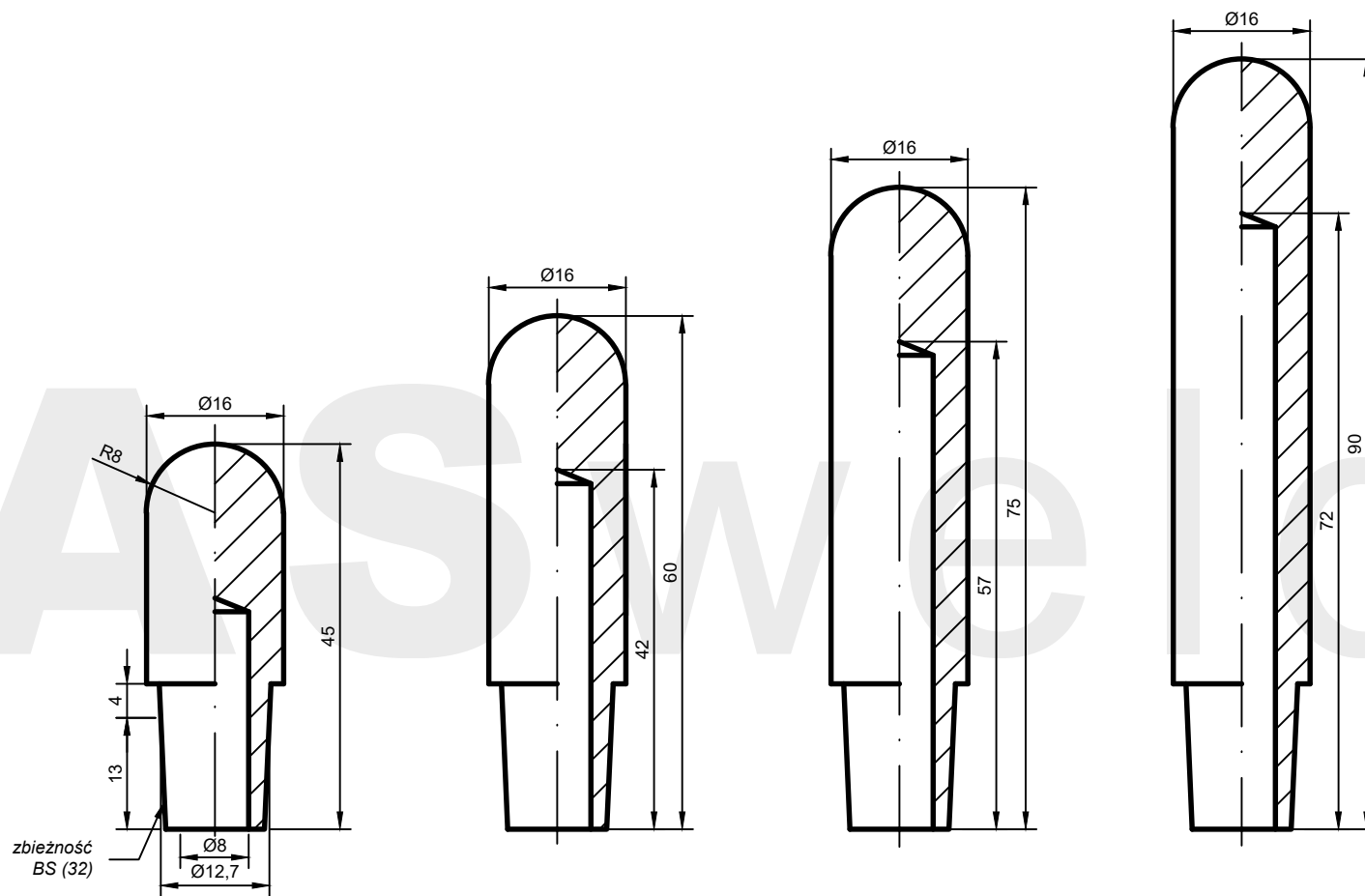

AW: F-16.45-32*

AW: F-16.60-32

AW: F-16.75-32*

AW: F-16.90-32*

*wykonanie na zamówienie

ASweld

ELEKTRODA PROSTA
forma F

Chwył elektrody

32

Karta katalogowa

01-06-01-32

ASweld

ELEKTRODY ODSADZONE KUTE

STOŻEK NR 32

zbieżność BS Ø12,7

Karty katalogowe: 02-__-__-32

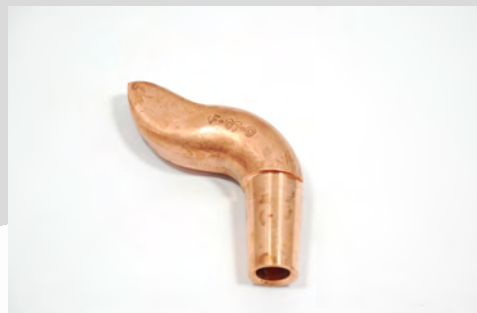

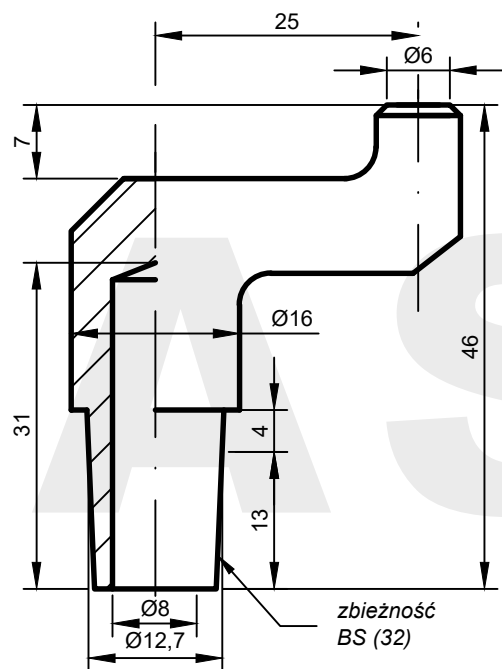

AW: F01(6)-16.46.25-32

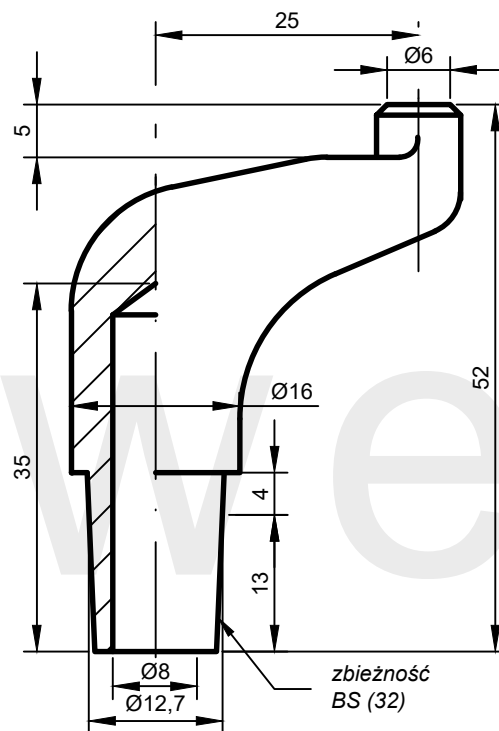

AW: F02(6)-16.52.25-32

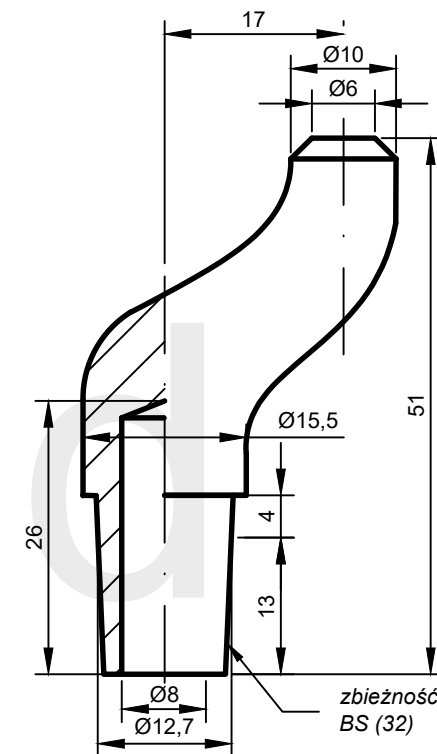

AW: F06(6)-15,5.51.17-32

*wykonanie na zamówienie

ASweld

ELEKTRODA ODSADZONA
KUTA

Chwył elektrody

32

Karta katalogowa

02-01-01-32

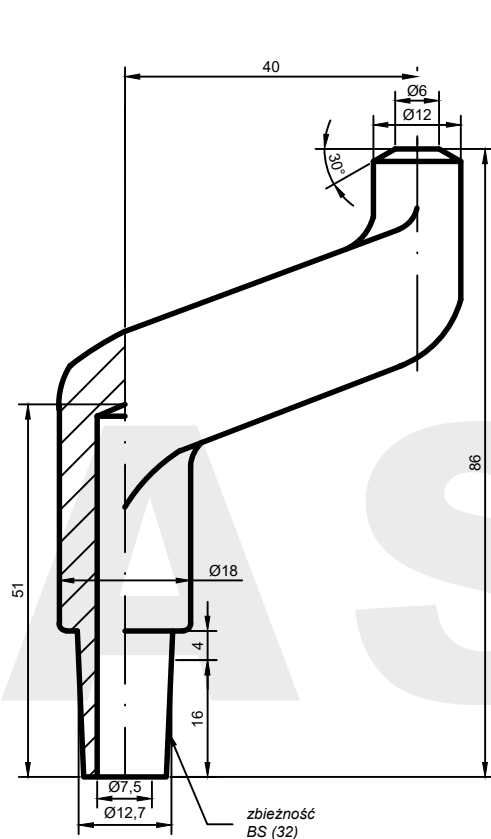

AW: F03(6)-18.86.40-32

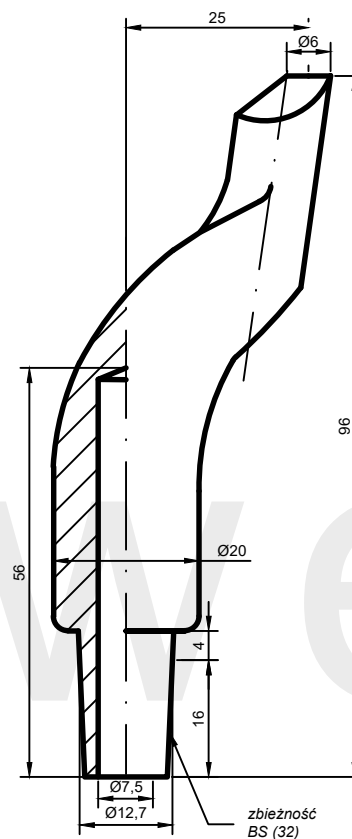

AW: F04(6)-20.96.25-32

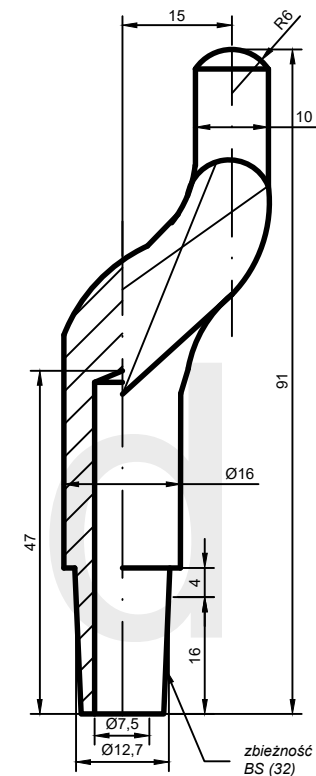

AW: F05(6)-16.91.15-32

*wykonanie na zamówienie

ASweld

ELEKTRODA ODSADZONA
KUTA

Chwył elektrody

32

Karta katalogowa

02-01-02-32

ASweld

ELEKTRODY ODSADZONE GIĘTE

STOŻEK NR 32

zbieżność BS Ø12,7

Karty katalogowe: 03-__-__-32

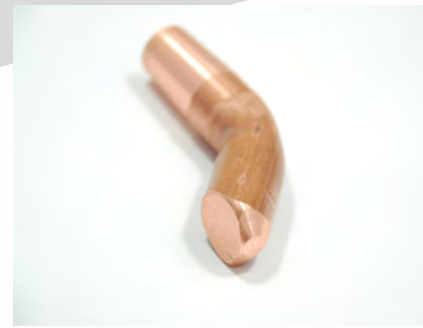

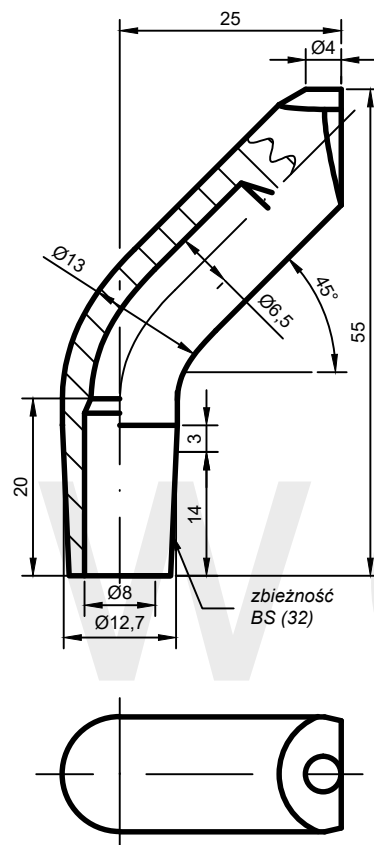

AW: G1(4)-13.55.25-32*

*wykonanie na zamówienie

ASweld

ELEKTRODA ODSADZONA
GIĘTA

Chwył elektrody

32

Karta katalogowa

03-01-01-32

ASweld

ELEKTRODY ODSADZONE PODWÓJNIE GIĘTE

STOŻEK NR 32

zbieżność BS Ø12,7

Karty katalogowe: 04-__-__-32



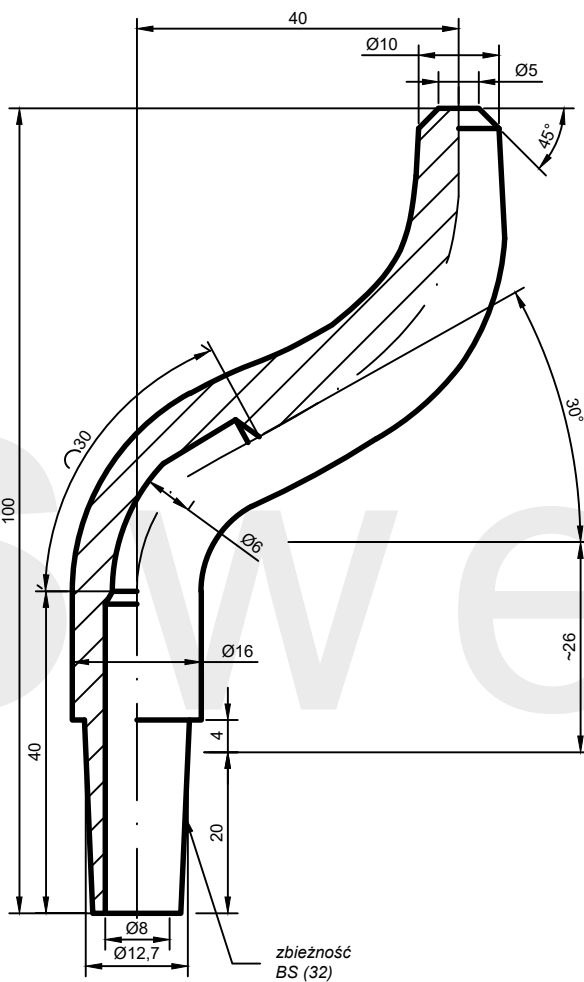

AW: G2B1(5)-16.100.40-32*

*wykonanie na zamówienie

ASweld

ELEKTRODA ODSADZONA
PODWÓJNIE GIĘTA

Chwyty elektrody

32

Karta katalogowa

04-01-01-32

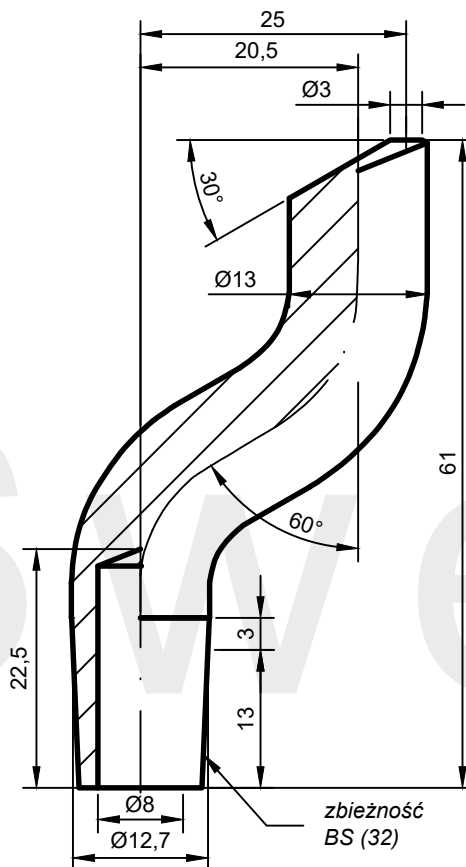

AW: G2D(3)-13.61.25-32

*wykonanie na zamówienie

ASweld

ELEKTRODA ODSADZONA
PODWÓJNIE GIĘTA

Chwył elektrody

32

Karta katalogowa

04-01-02-32

ASweld

ELEKTRODY PŁASKIE

STOŻEK NR 32

zbieżność BS $\varnothing 12,7$

Karty katalogowe: 05-__-__-32



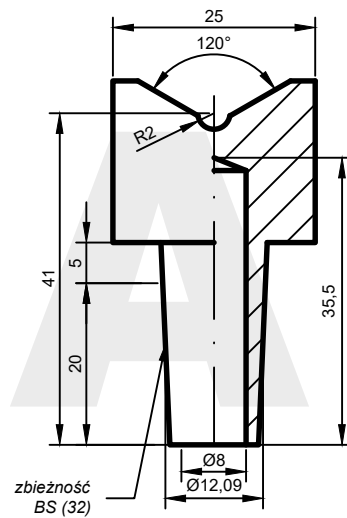

AW: V120-20x25.45-32*

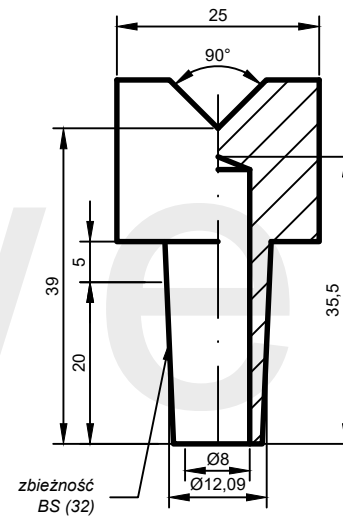
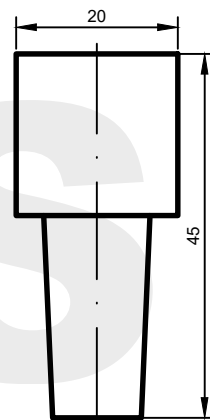

AW: V90-20x25.45-32*

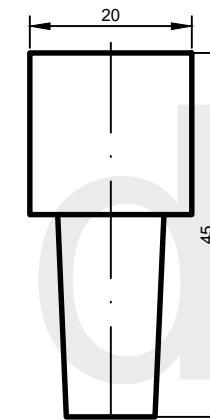

*wykonanie na zamówienie

ASweld

ELEKTRODA PŁASKA
Z PRYZMĄ

Chwył elektrody

32

Karta katalogowa

05-02-01-32

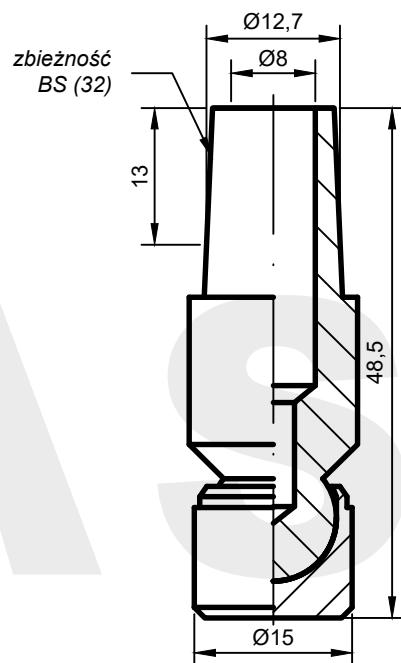

AW: PK12-15.48-32*

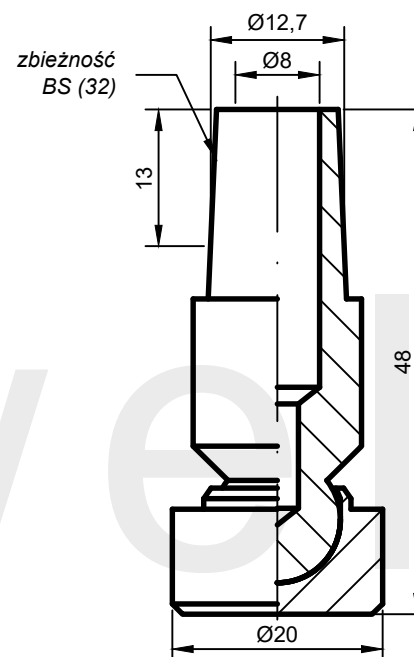

AW: PK12-20.48-32*

*wykonanie na zamówienie

ASweld

ELEKTRODA WAHLIWA
przegub K12

Chwył elektrody

32

Karta katalogowa

05-04-01-32

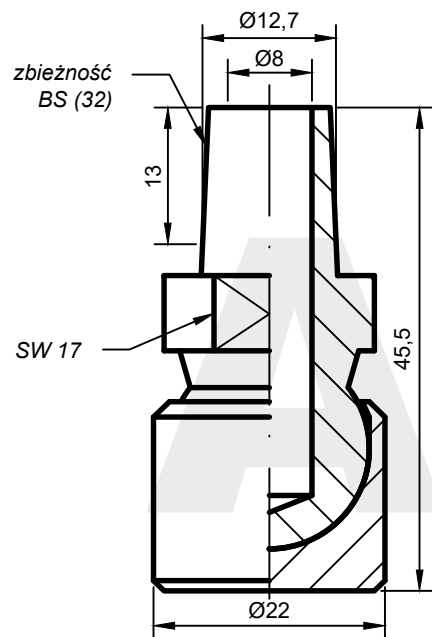

AW: PK19-22.46-32

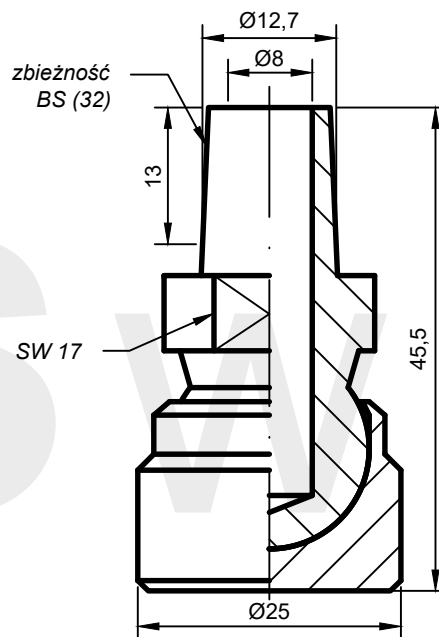

AW: PK19-25.46-32

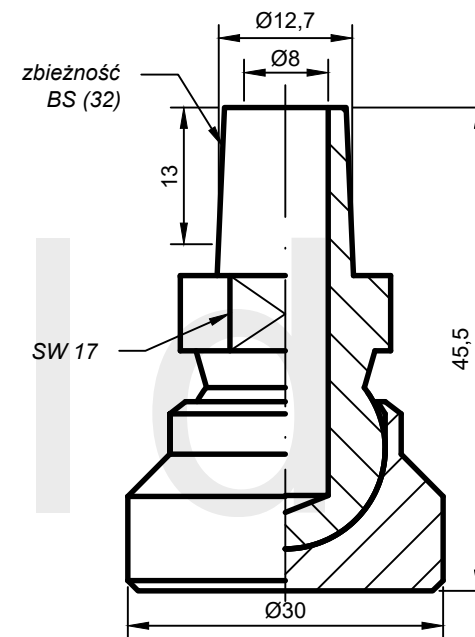

AW: PK19-30.46-32*

*wykonanie na zamówienie

ASweld

ELEKTRODA WAHLIWA
przegub K19

Chwył elektrody

32

Karta katalogowa

05-04-02-32

ASweld

OBSADY ELEKTROD NASADKOWYCH

STOŻEK NR 32

zbieżność BS $\varnothing 12,7$

Karty katalogowe: 06-__-__-32



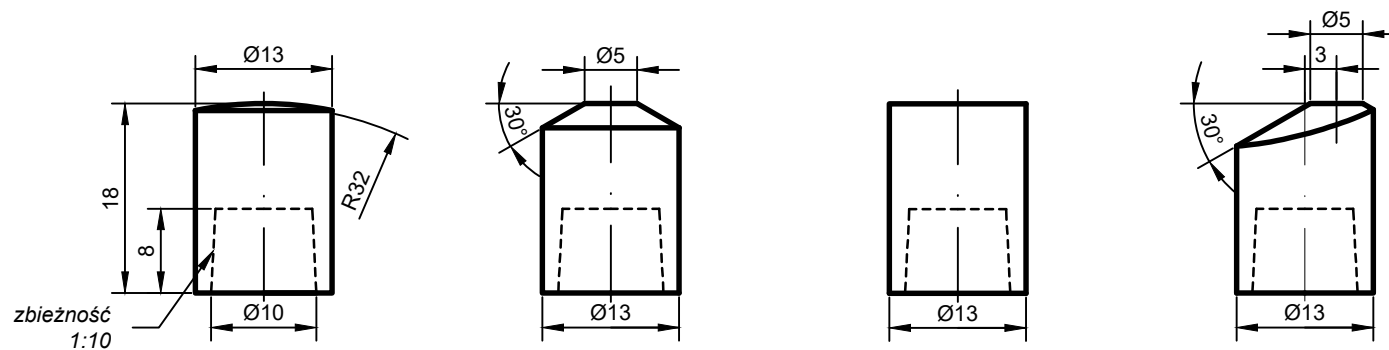

Typ: N-A13

Typ: N-B13

Typ: N-C13

Typ: N-D13

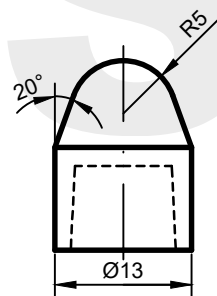

Typ: N-E13

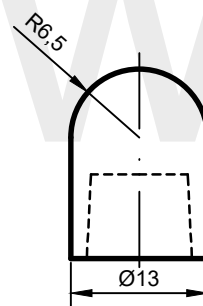

Typ: N-F13

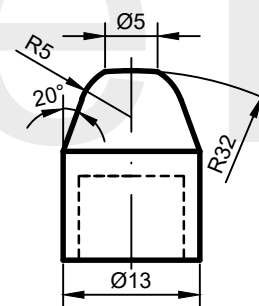

Typ: N-G13

*wykonanie na zamówienie

ASweld

ELEKTRODA NASADKOWA
rozmiar 13

Chwyt elektrody

51

Karta katalogowa

06-00-01-51

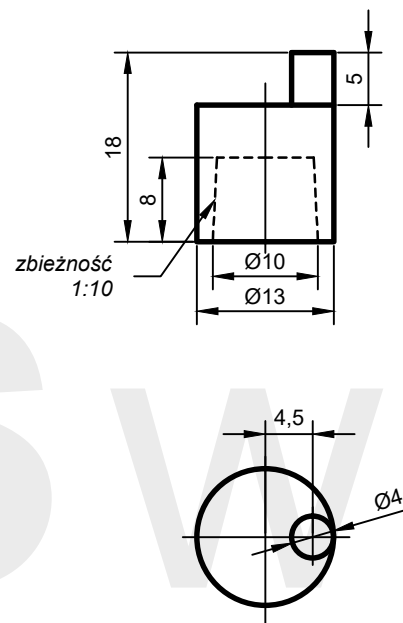

AW: N-C13(4.5)

*wykonanie na zamówienie

ASweld

ELEKTRODA NASADKOWA
rozmiar 13

Chwył elektrody

51

Karta katalogowa

06-00-02-51

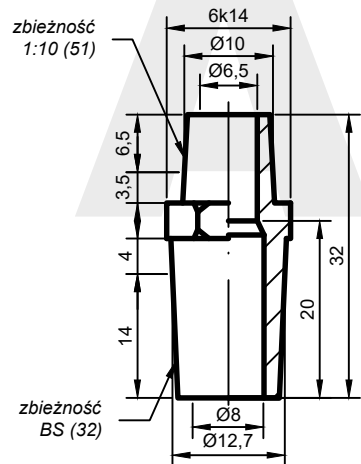

AW: TR51-6k14.32-32*

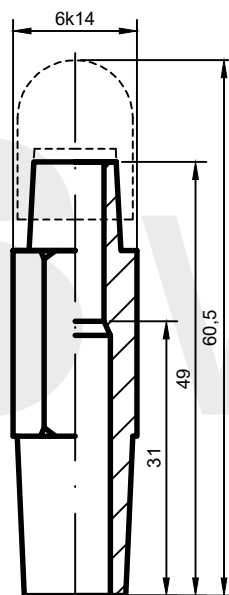

AW: TR51-6k14.49-32

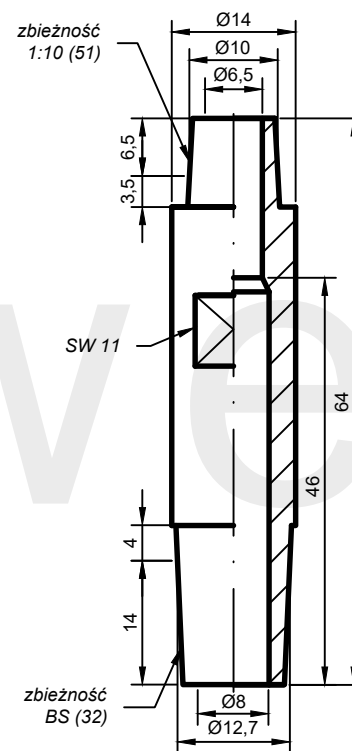

AW: TR51-14.64-32*

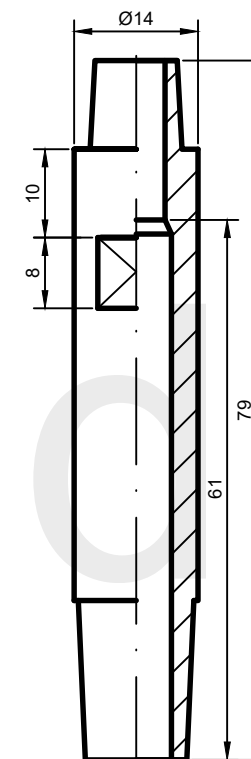

AW: TR-14.79-32/51*

*wykonanie na zamówienie

ASweld

OBSADA ELEKTROD NASADKOWYCH
TRZON PROSTY Z OTWOREM PRZELOTOWYM

Mocowanie

32/51

Karta katalogowa

06-01-01-32

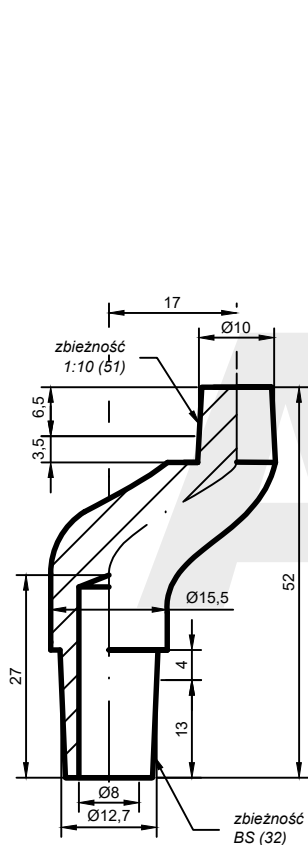

AW: TR51-F06-32

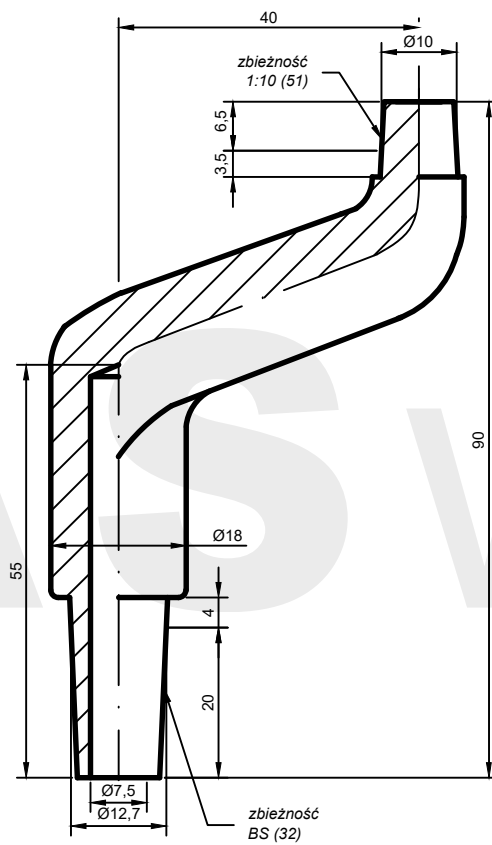

AW: TR51-F03-32

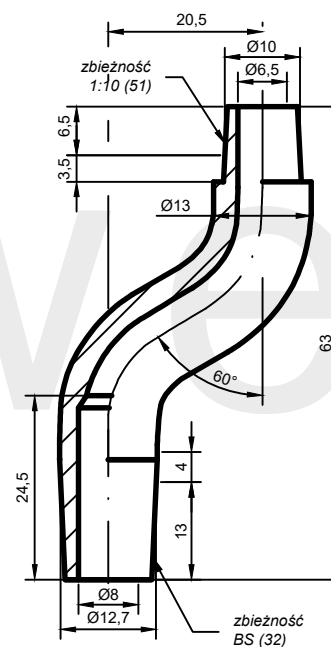

AW: TR51-13.63.20,5-32

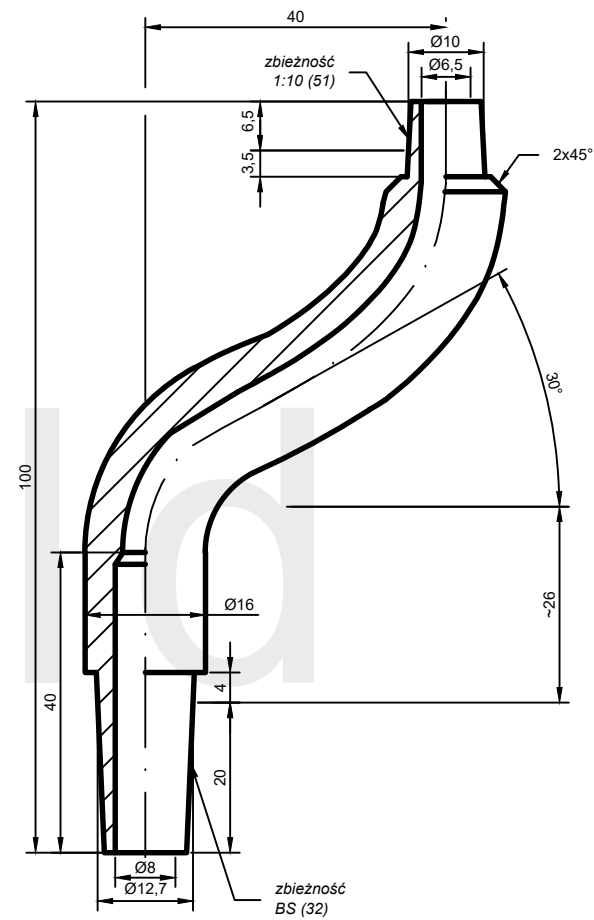

AW: TR51-16.100.40-32

*wykonanie na zamówienie

ASweld

OBSADY ELEKTROD GRZYBKOWYCH I WKRETEK ELEKTRODOWYCH

STOŻEK NR 32

zbieżność BS $\varnothing 12,7$

Karty katalogowe: 07-__-__-32



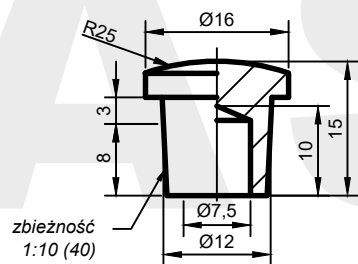

AW: A(25)-16.15-40

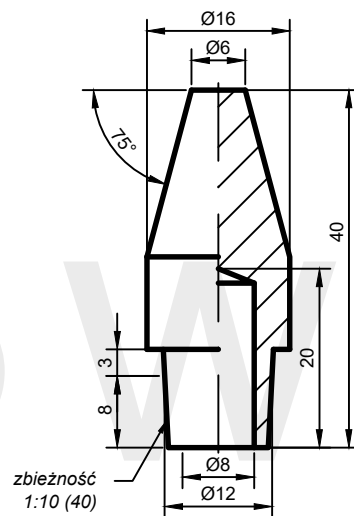

AW: B3(6)-16.40-40

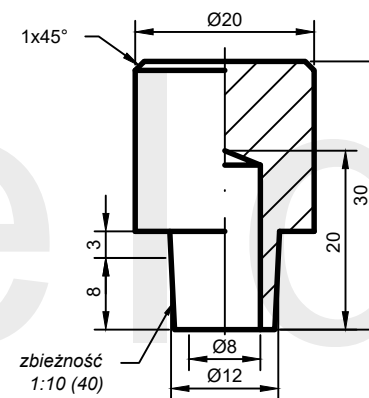

AW: C-20.30-40

*wykonanie na zamówienie

ASweld

ELEKTRODA GRZYBKOWA

Chwyt elektrody

40

Karta katalogowa

07-00-01-40

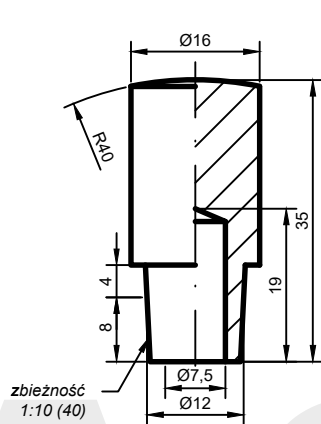

AW: A(4)-16.35-40

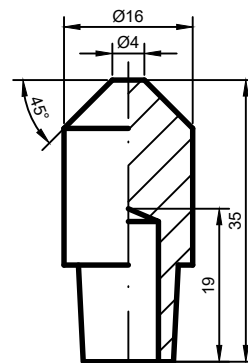

AW: B1(4)-16.35-40

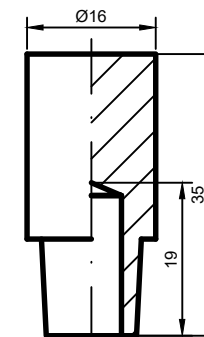

AW: C-16.35-40

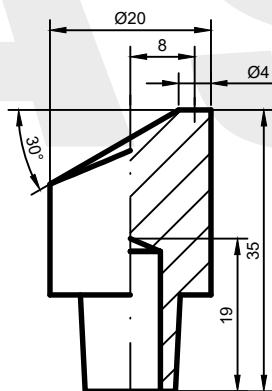

AW: D(4)-20.35-40

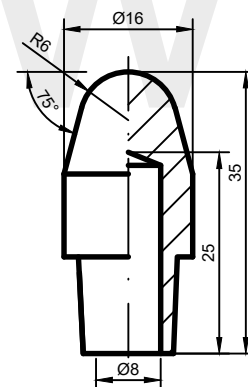

AW: E3(6)-16.35-40

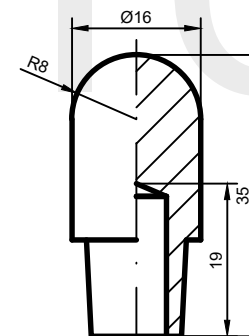

AW: F-16.35-40

*wykonanie na zamówienie

ASweld

ELEKTRODA GRZYBKOWA

Chwył elektrody

40

Karta katalogowa

07-00-02-40

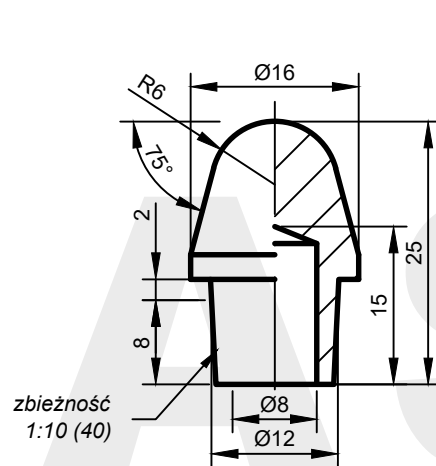

AW: E3(6)-16.25-40

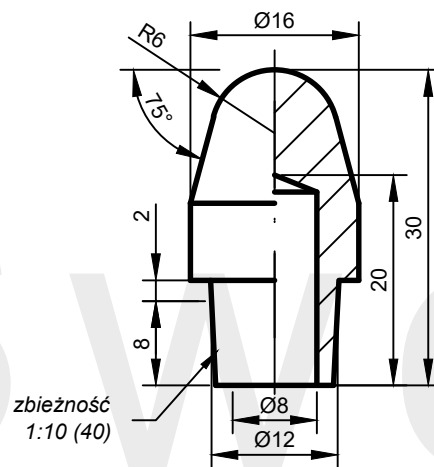

AW: E3(6)-16.30-40

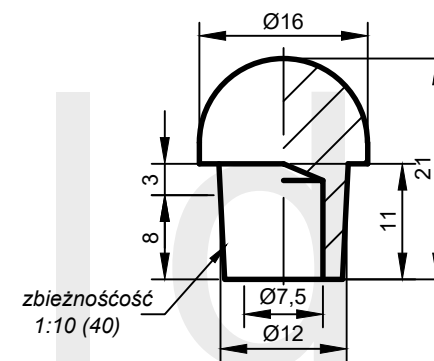

AW: F-16.21-40

*wykonanie na zamówienie

ASweld

ELEKTRODA GRZYBKOWA

Chwyt elektrody

40

Karta katalogowa

07-00-03-40

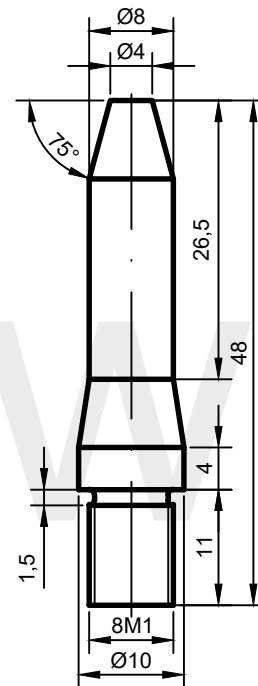

AW: B3(4)-10(8).48-8M1

*wykonanie na zamówienie

ASweld

WKRETKA ELEKTRODOWA

Mocowanie

8M1

Karta katalogowa

07-00-04-8M1

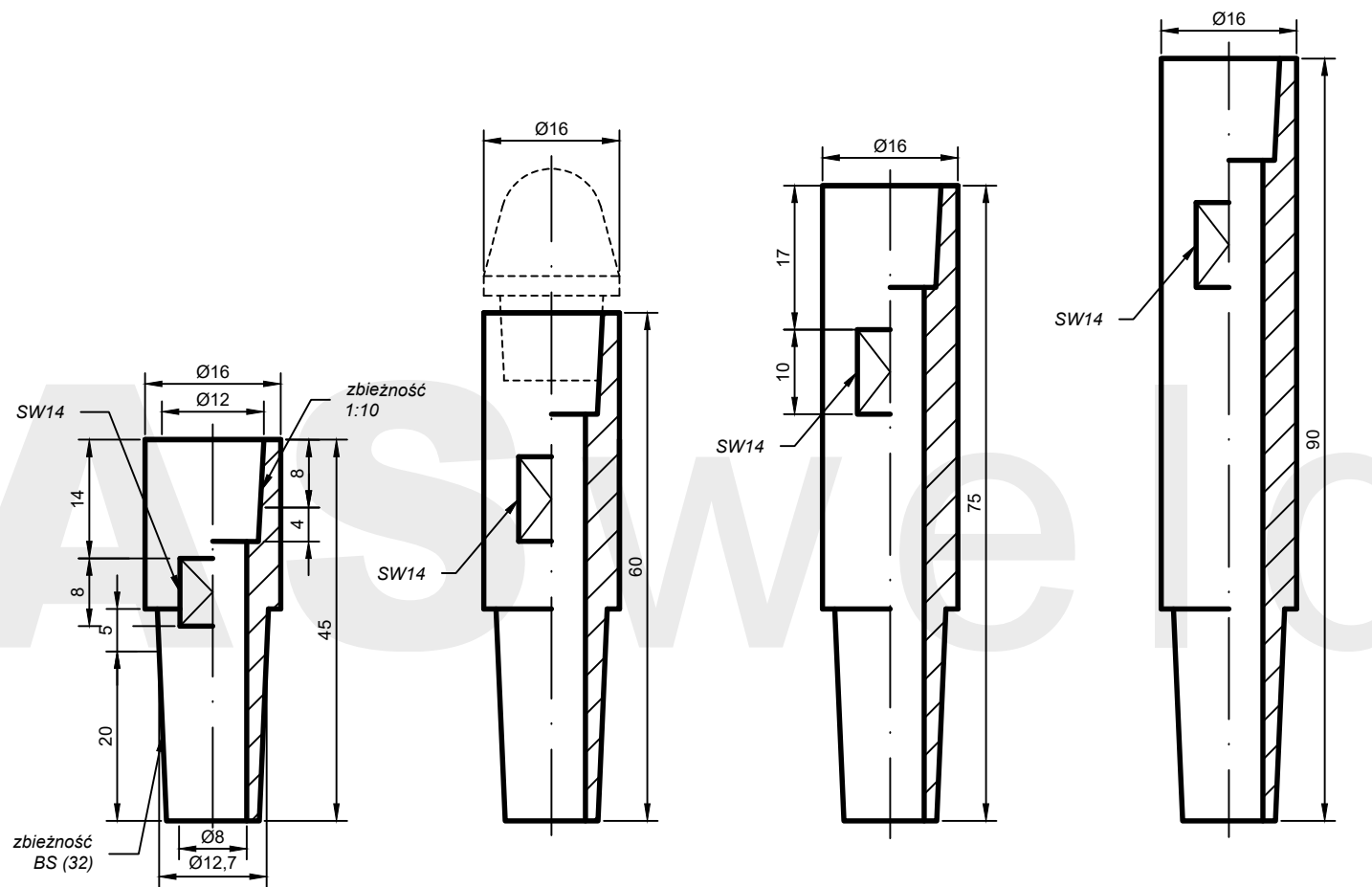

AW: GN40-16.45-32*

AW: GN40-16.60-32

AW: GN40-16.75-32*

AW: GN40-16.90-32*

*wykonanie na zamówienie

ASweld

OBSADA ELEKTROD GRZYBKOWYCH
PROSTA

Mocowanie

32/40

Karta katalogowa

07-01-01-32

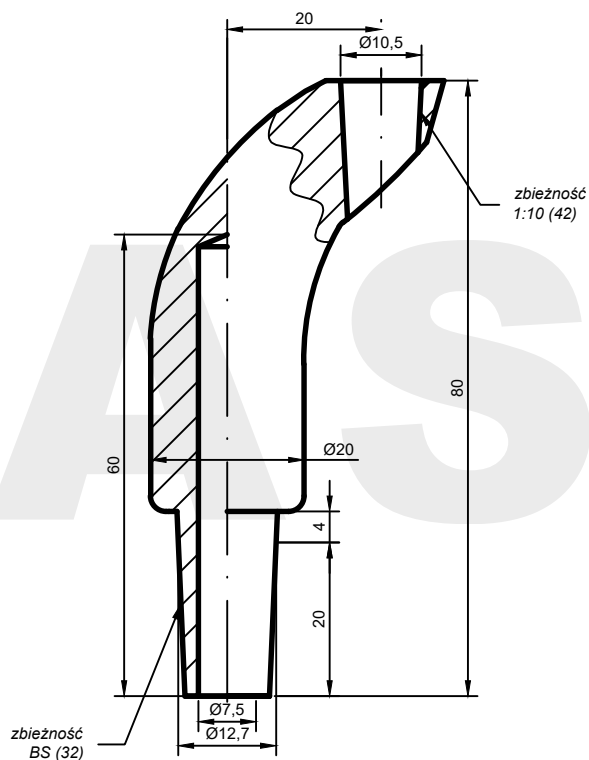

AW: GN42-20.80.20-32

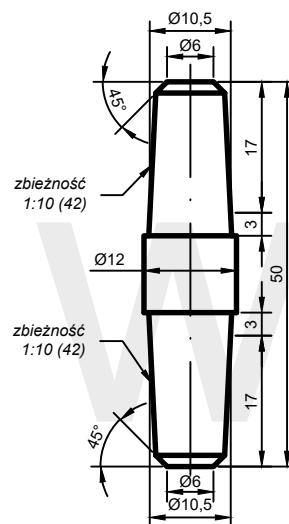

AW: B42(6)-12.50-42(17)

AW: B42(6)-12.50-42(17)Be*

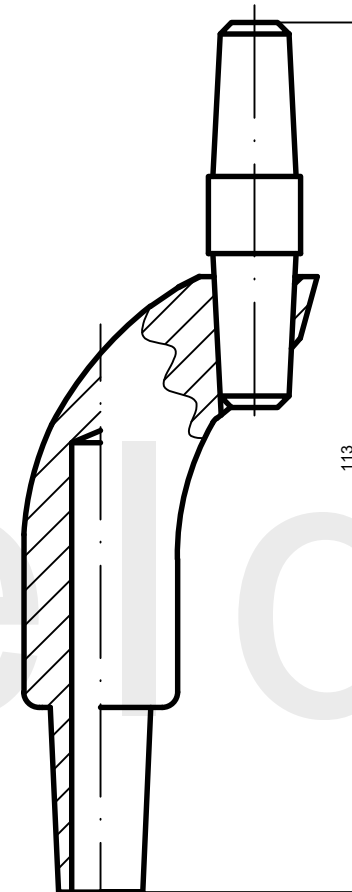

*wykonanie na zamówienie

ASweld

ADAPTER ELEKTRODOWY
GNIAZDO ODSADZONE Z ELEKTRODĄ BERYLOWĄ

Mocowanie

32

Karta katalogowa

07-03-01-32

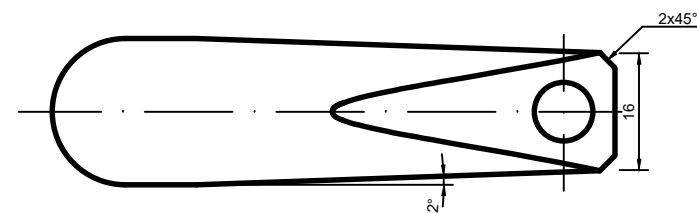
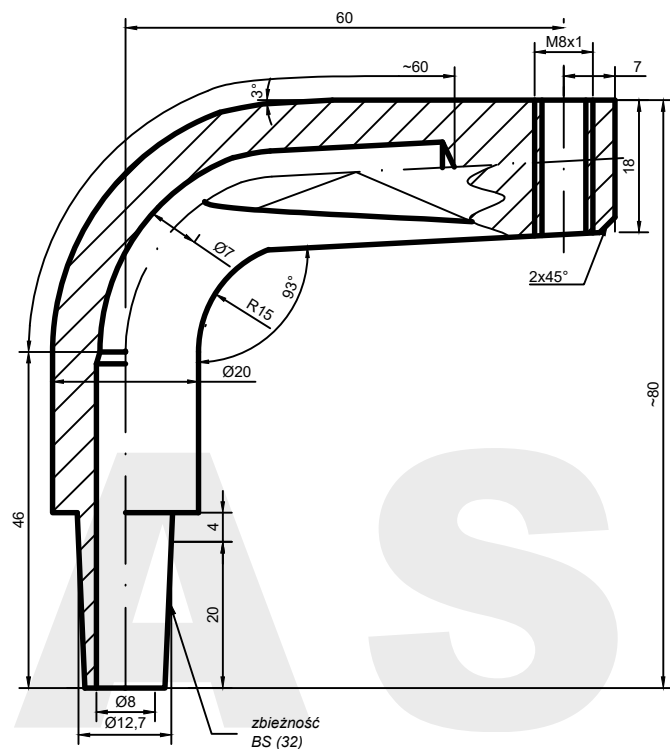

AW: GN8M1-20.80.60-32

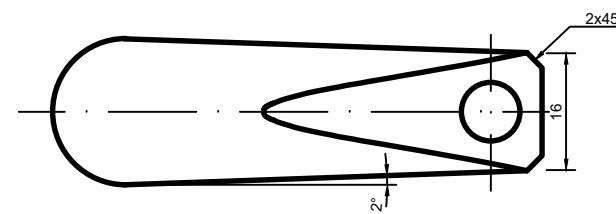
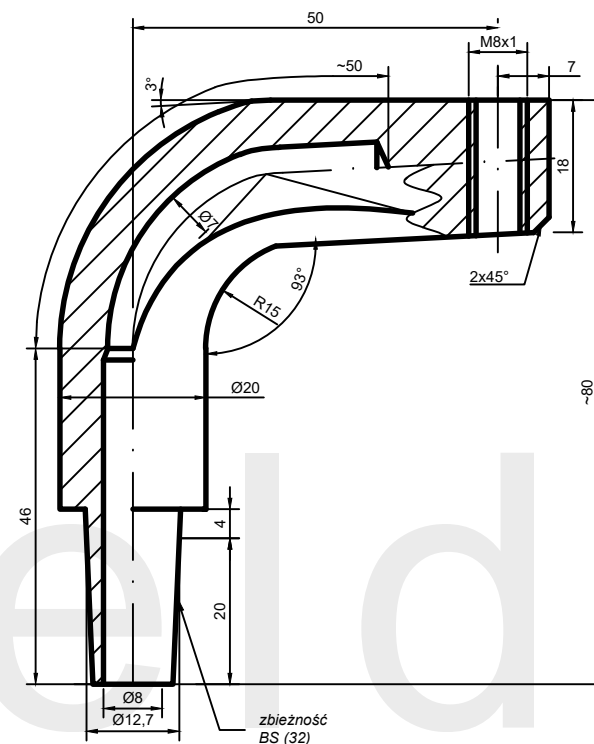

AW: GN8M1-20.80.50-32 *wykonanie na zamówienie

ASweld

OBSADA DLA WKRETEK ELEKTRODOWYCH
ODSADZONA

Mocowanie

32

Karta katalogowa

07-05-01-32

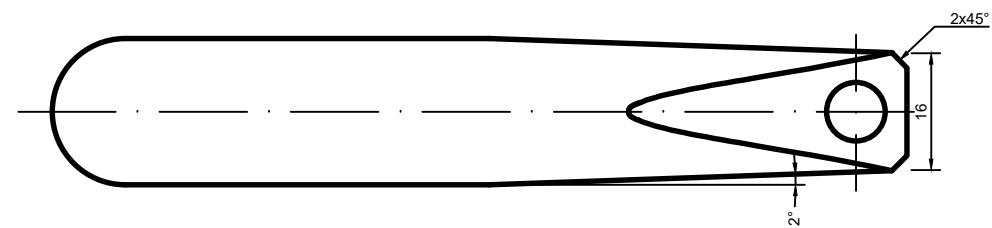
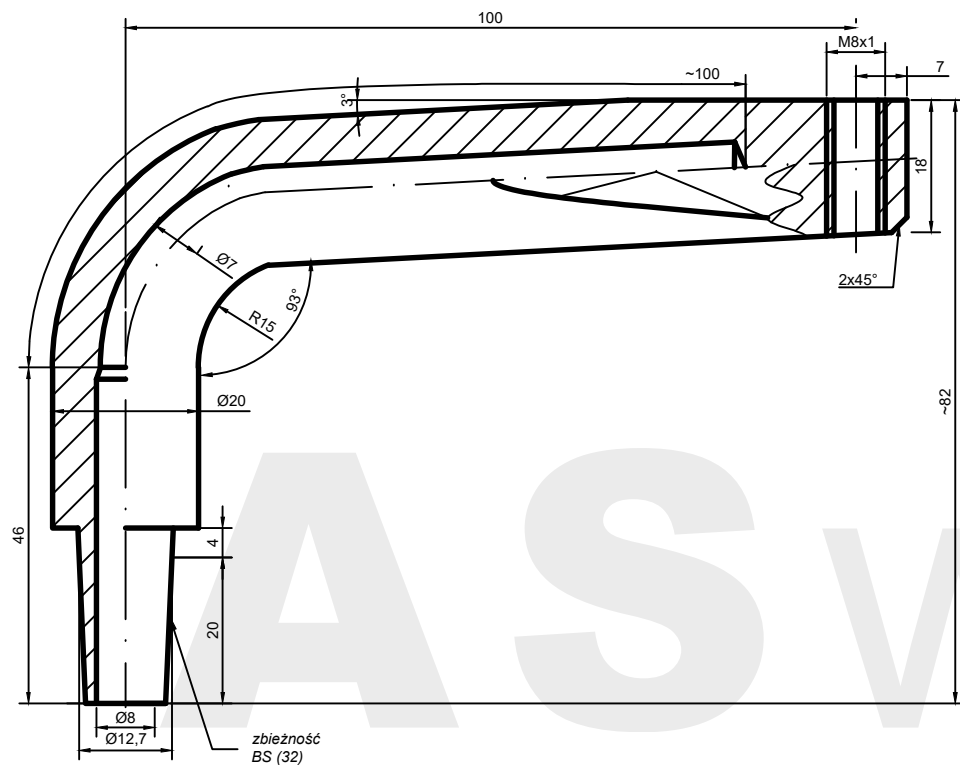

AW: GN8M1-20.82.100-32

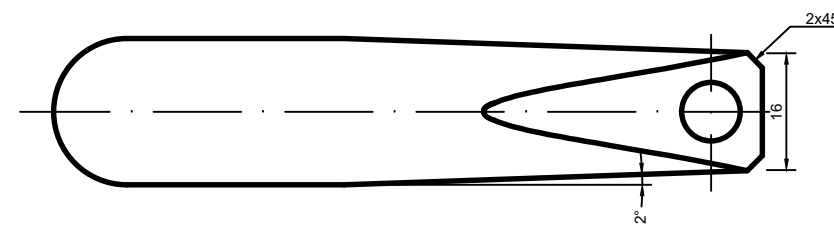
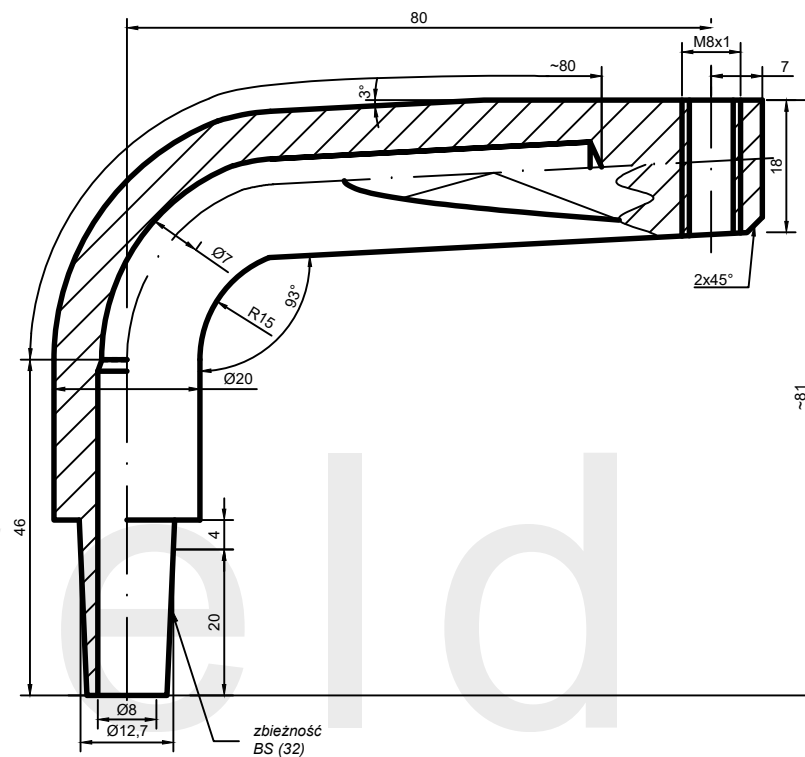

AW: GN8M1-20.81.80-32 *wykonanie na zamówienie

ASweld

OBSADA DLA WKRETEK ELEKTRODOWYCH
ODSADZONA

Mocowanie

32

Karta katalogowa

07-05-02-32

ASweld

ELEKTRODY DO ZGRZEWANIA ŚRUB I NAKRĘTEK

STOŻEK NR 32

zbieżność BS $\text{Ø}12,7$

Karty katalogowe: 08-__-__-32



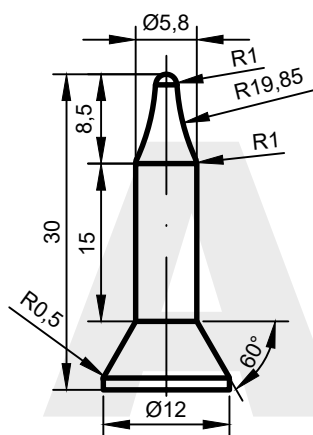

AW: PA-M5-KCF

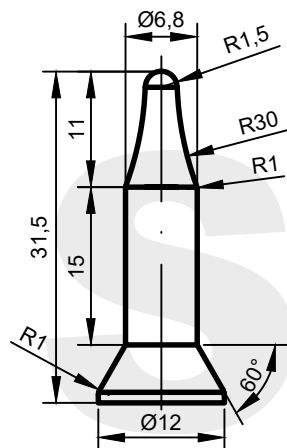

AW: PA-M6-KCF
PA-M6-CER

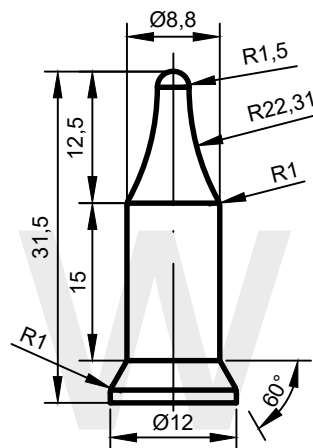

AW: PA-M8-KCF
PA-M8-CER

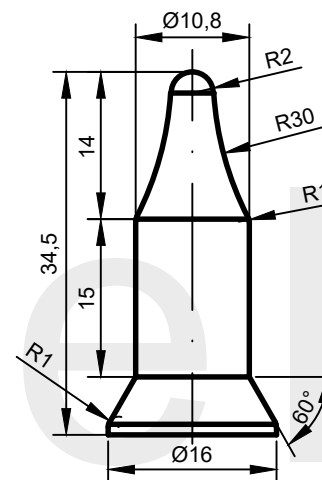

AW: PA-M10-KCF

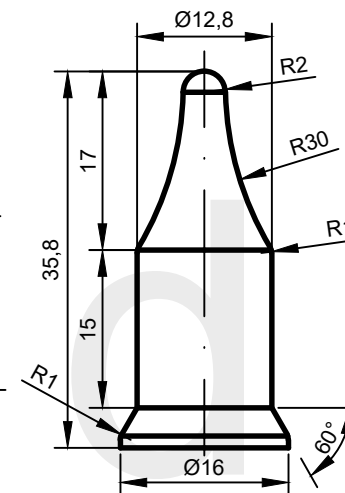

AW: PA-M12-KCF

*wykonanie na zamówienie

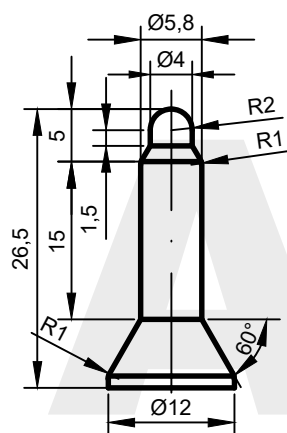

AW: PR-M5-KCF

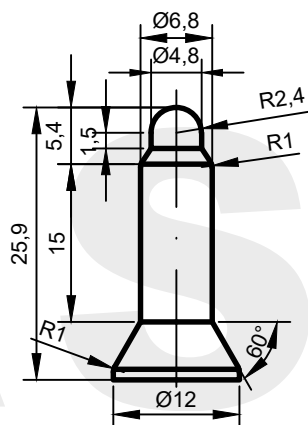

AW: PR-M6-KCF

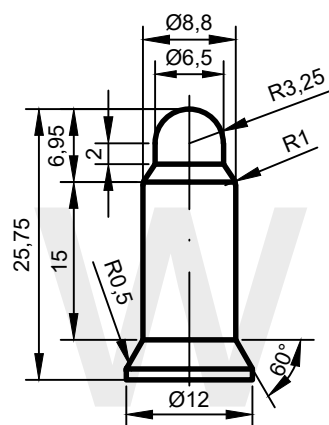

AW: PR-M8-KCF

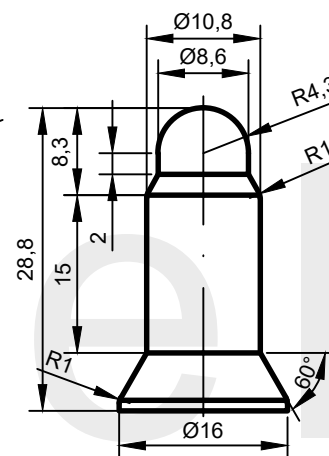

AW: PR-M10-KCF

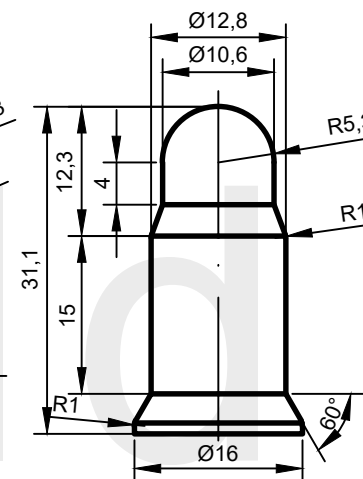

AW: PR-M12-KCF

*wykonanie na zamówienie

ASweld

**PINY DO ZGRZEWANIA
DO RĘCZNEGO PODAWANIA NAKRĘTEK**

Karta katalogowa

08-00-02-00

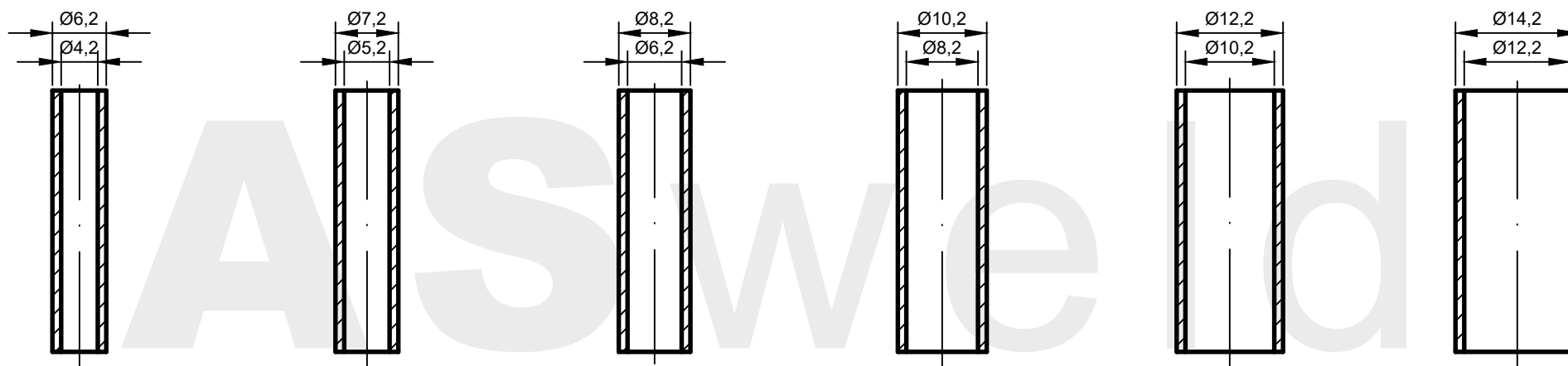

AW: T-M4-KCF

AW: T-M5-KCF

AW: T-M6-KCF

AW: T-M8-KCF

AW: T-M10-KCF

AW: T-M12-KCF

*wykonanie na zamówienie

ASweld

TULEJA Z KCF
DO ZGRZEWANIA ŚRUB

Karta katalogowa

08-00-03-00

Pin do zgrzewania		A [mm]
ręcznego	automatycznego	
PR-M5-KCF	PA-M5-KCF	5.8
PR-M6-KCF	PA-M6-KCF	6.8
PR-M8-KCF	PA-M8-KCF	8.8

PA-M6-CER	6.8
PA-M8-CER	8.8

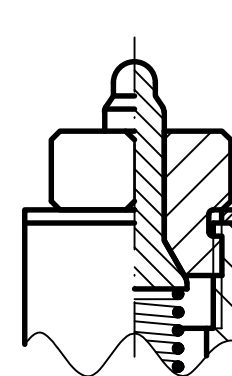
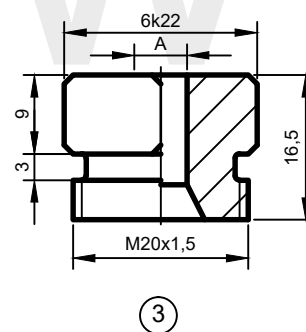
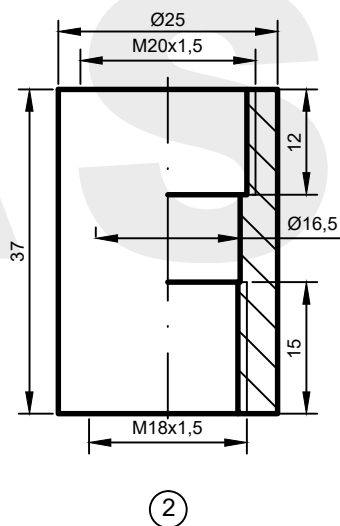
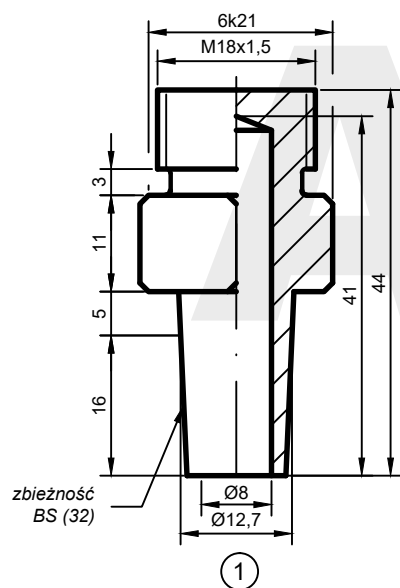

Elektroda z pinem do ręcznego podawania nakrętek

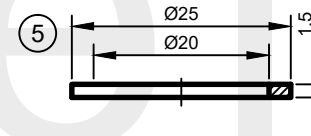

AW: P20-25.1,5

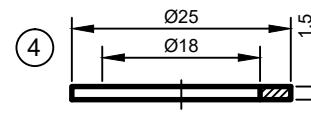

AW: P18-25.1,5

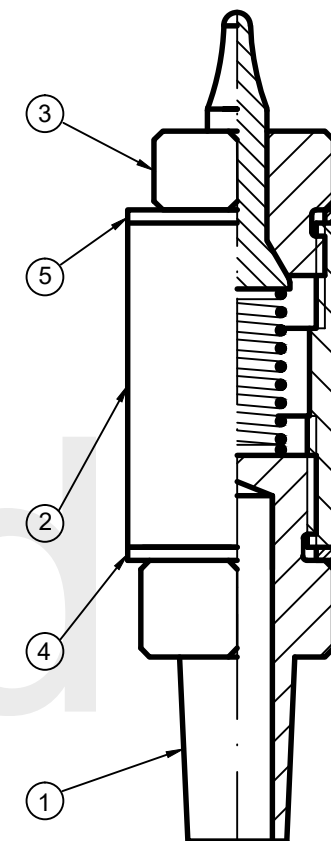

Elektroda z pinem do automatycznego podawania nakrętek

AW: TR-6k22.44-32/18M1,5

AW: KR20M1,5-25.37-18M1,5

AW: WA-6k22.17-20M1,5

ASweld

**ELEKTRODA Z PINEM
DO ZGRZEWANIA NAKRĘTEK**

Chwył elektrody

32

Karta katalogowa

08-01-01-32

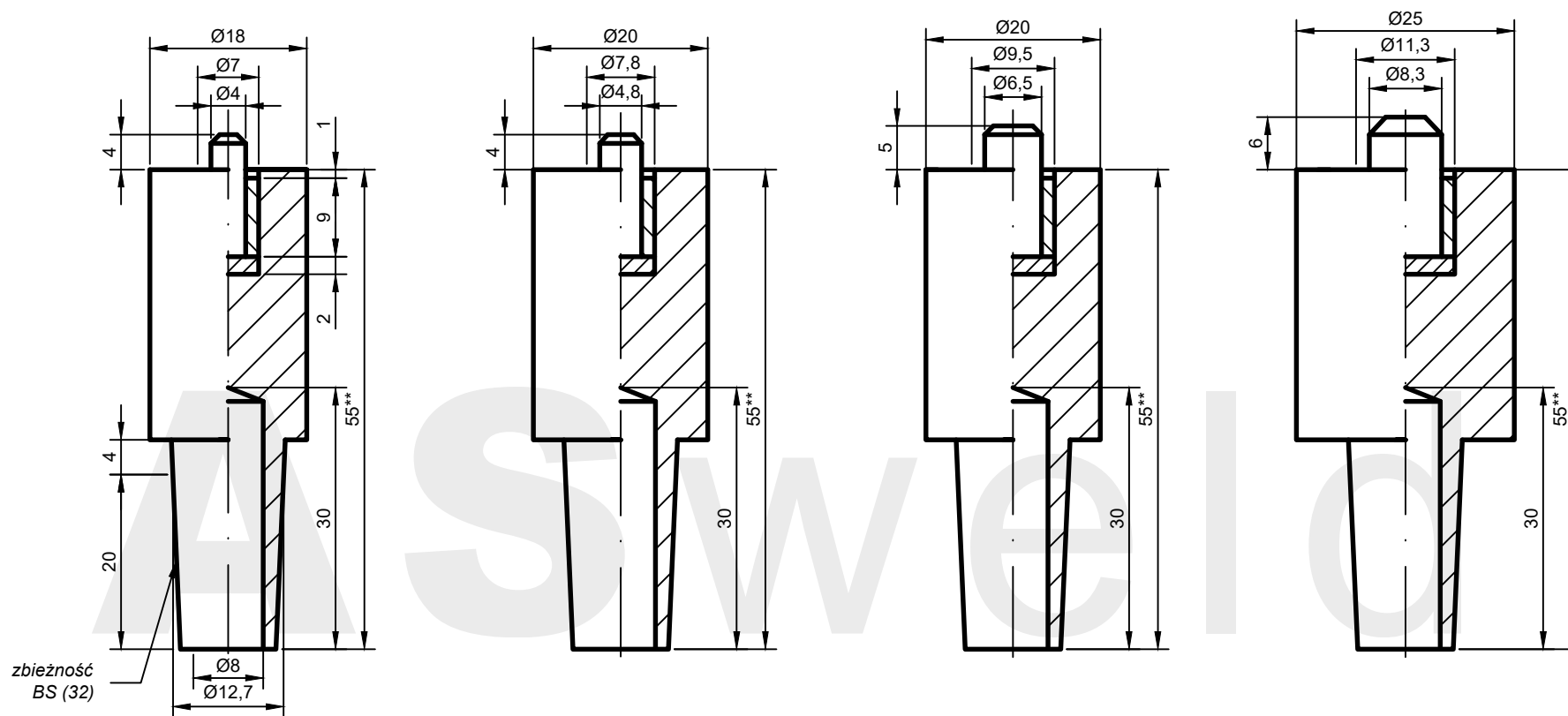

AW: M5N-18.55-32*

AW: M6N-20.55-32*

AW: M8N-20.55-32*

AW: M10N-25.55-32*

*wykonanie na zamówienie

**możliwe inne długości wg uzgodnień

ASweld

ELEKTRODA PROSTA
DO ZGRZEWANIA NAKRĘTEK TYPU DIN 929

Chwyt elektrody

32

Karta katalogowa

08-01-02-32

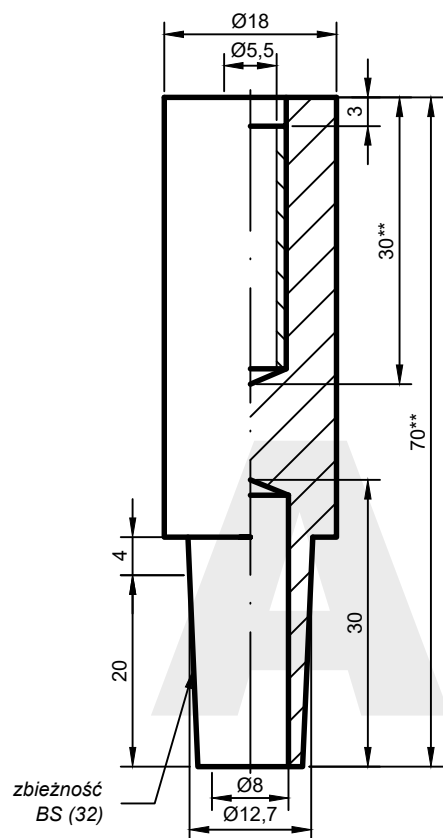

AW: M5S-18.70-32*

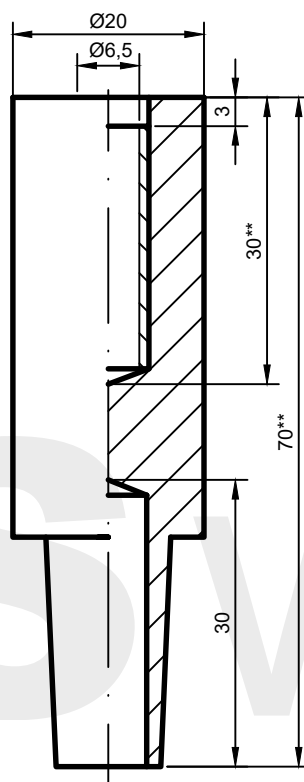

AW: M6S-20.70-32*

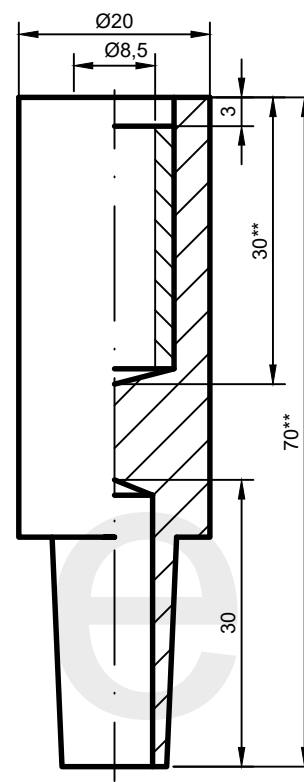

AW: M8S-20.70-32*

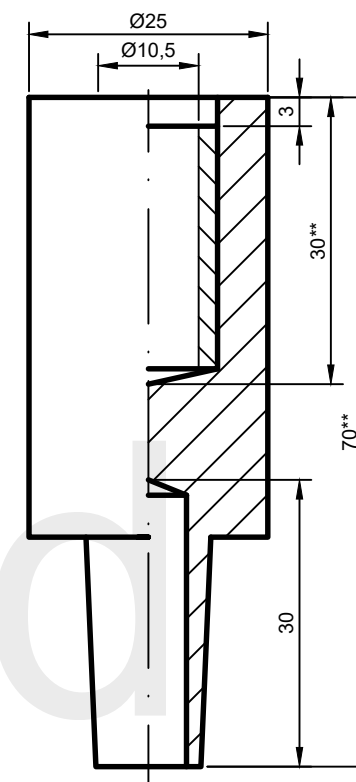

AW: M10S-25.70-32*

*wykonanie na zamówienie
**możliwe inne długości wg uzgodnień

ASweld

ELEKTRODA PROSTA
DO ZGRZEWANIA ŚRUB TYPU DIN 34817

Chwyt elektrody

32

Karta katalogowa

08-02-02-32

ELEKTRODY WOLFRAMOWE

STOŻEK NR 32

zbieżność BS $\varnothing 12,7$

Karty katalogowe: 09-__-__-32



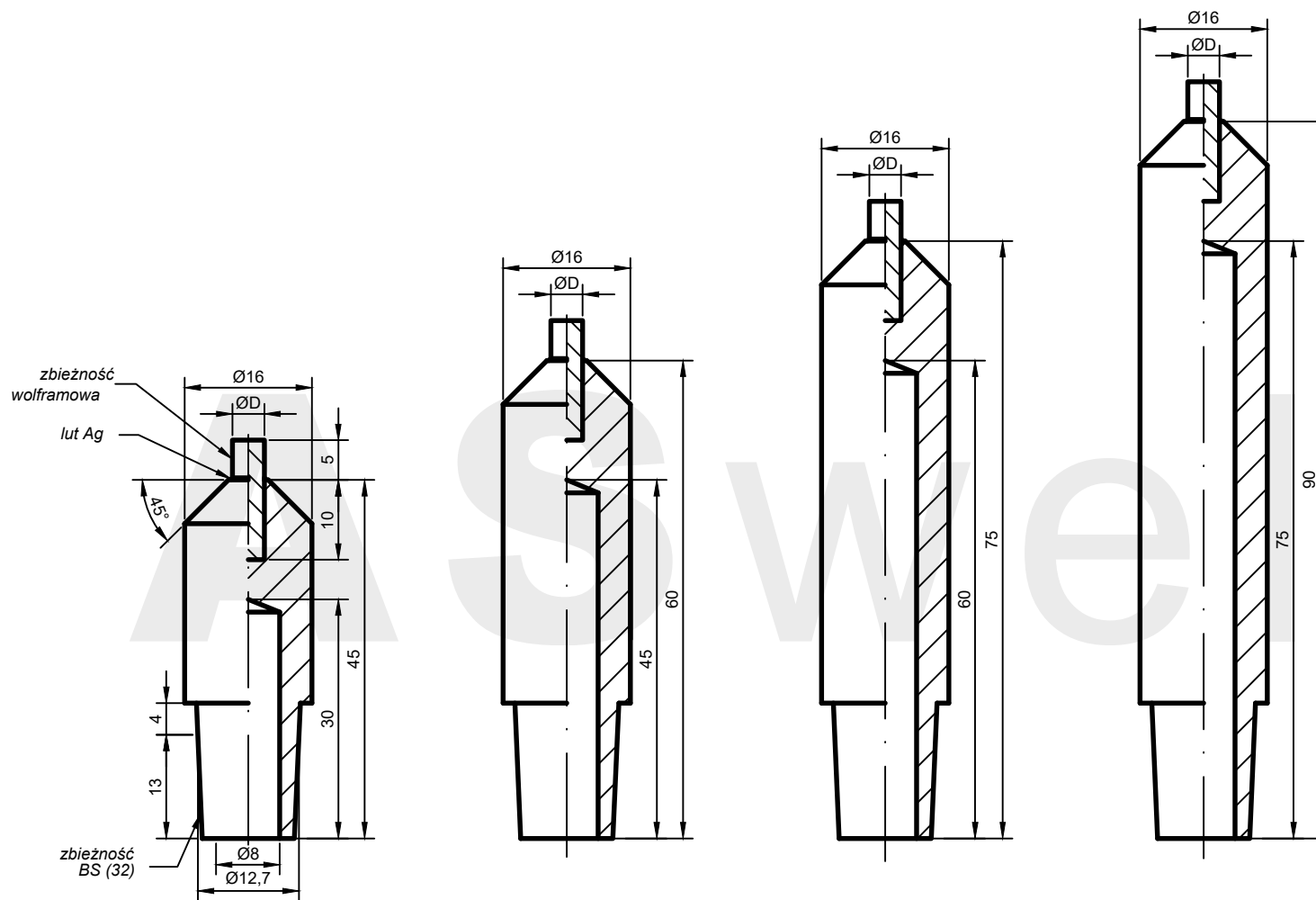

AW: WØD-16.45-32*

AW: WØD-16.60-32*

AW: WØD-16.75-32*

AW: WØD-16.90-32*

ØD
3,2
4
4,8
6
8
10

*wykonanie na zamówienie

ASweld

ELEKTRODA PROSTA
Z WKŁADKĄ WOLFRAMOWĄ DO ZGRZEWANIA MIEDZI

Chwył elektrody

32

Karta katalogowa

09-01-01-32

ASweld

ŚWIECE ELEKTRODOWE

STOŻEK NR 32

zbieżność BS $\varnothing 12,7$

Karty katalogowe: 10-__-__-32



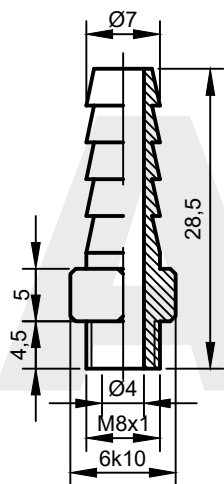

AW: K7-8M1

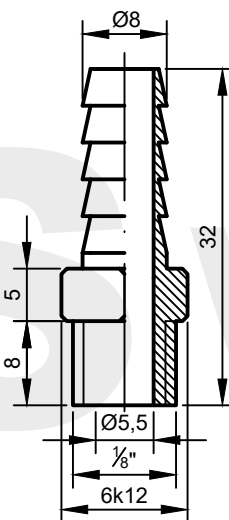

AW: K8-1G8

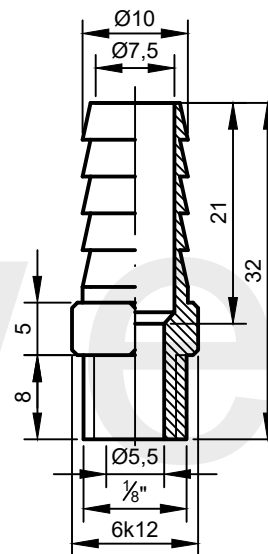

AW: K10-1G8

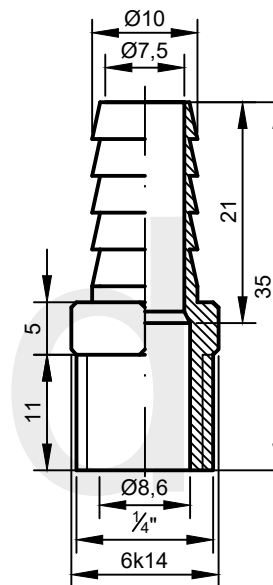

AW: K10-1G4

*wykonanie na zamówienie

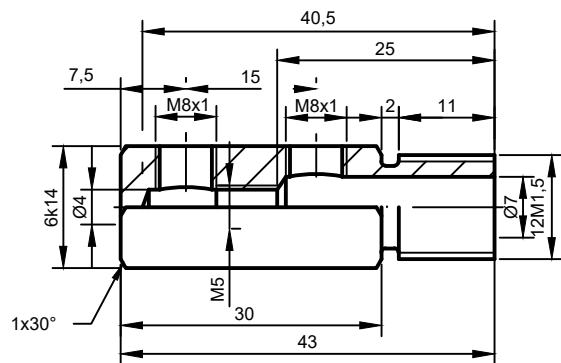

AW: R12M1,5-6k14.43-8M1*

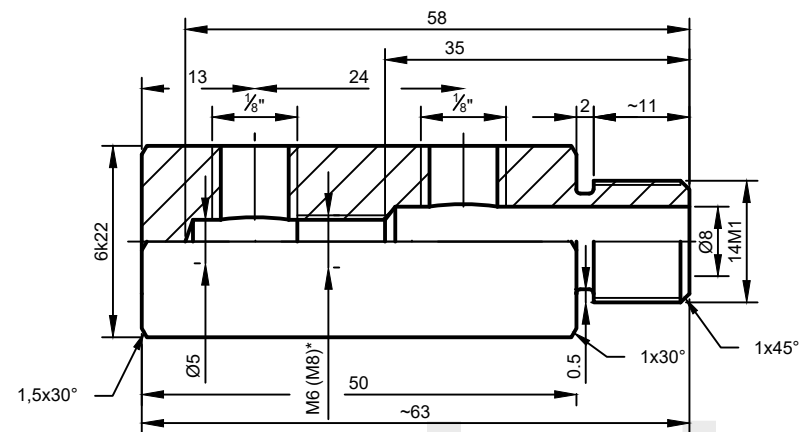

AW: R14M1-6k22.63-1G8

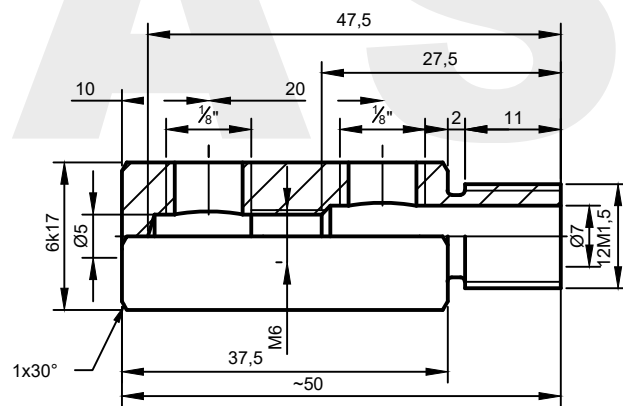

AW: R12M1,5-6k17.50-1G8*

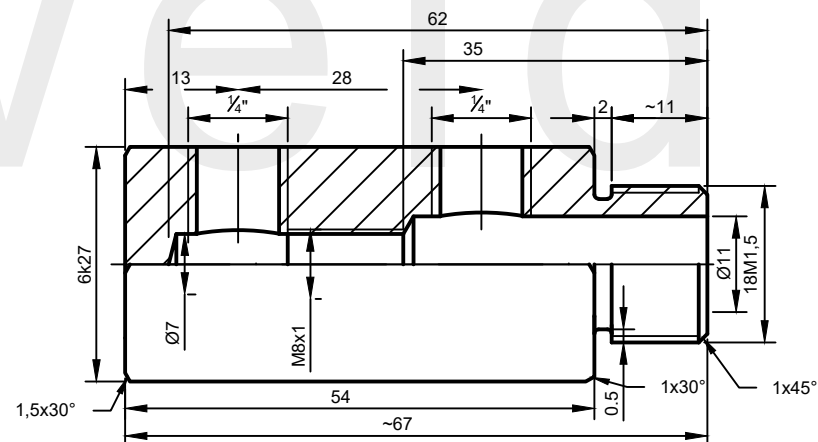

AW: R18M1,5-6k27.67-1G4*

*wykonanie na zamówienie

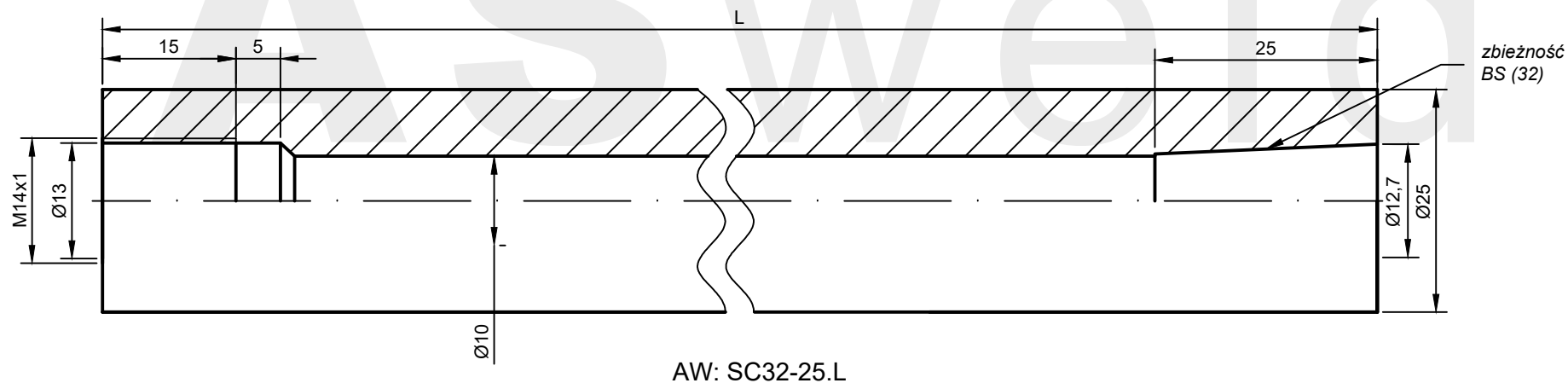
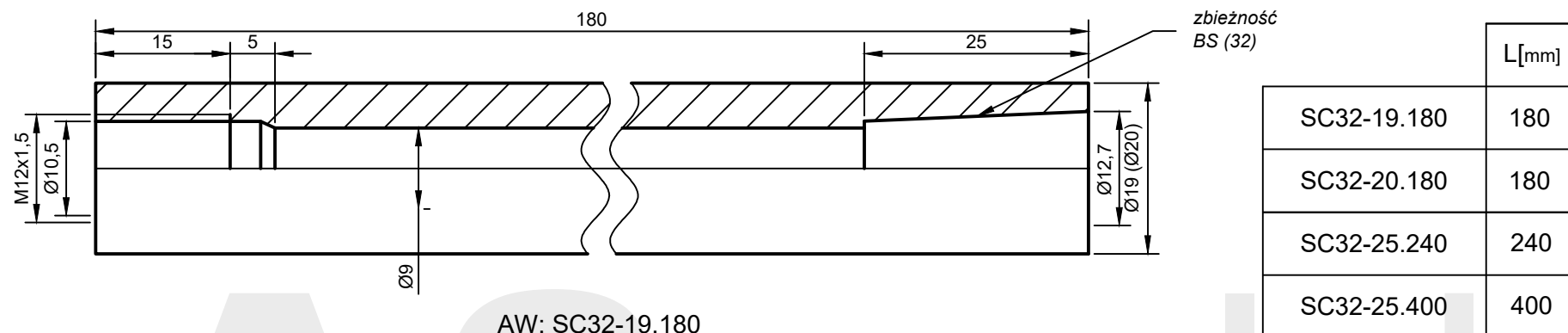

*wykonanie na zamówienie

ASweld

ŚWIECA

Mocowanie

32

Karta katalogowa

10-01-01-32

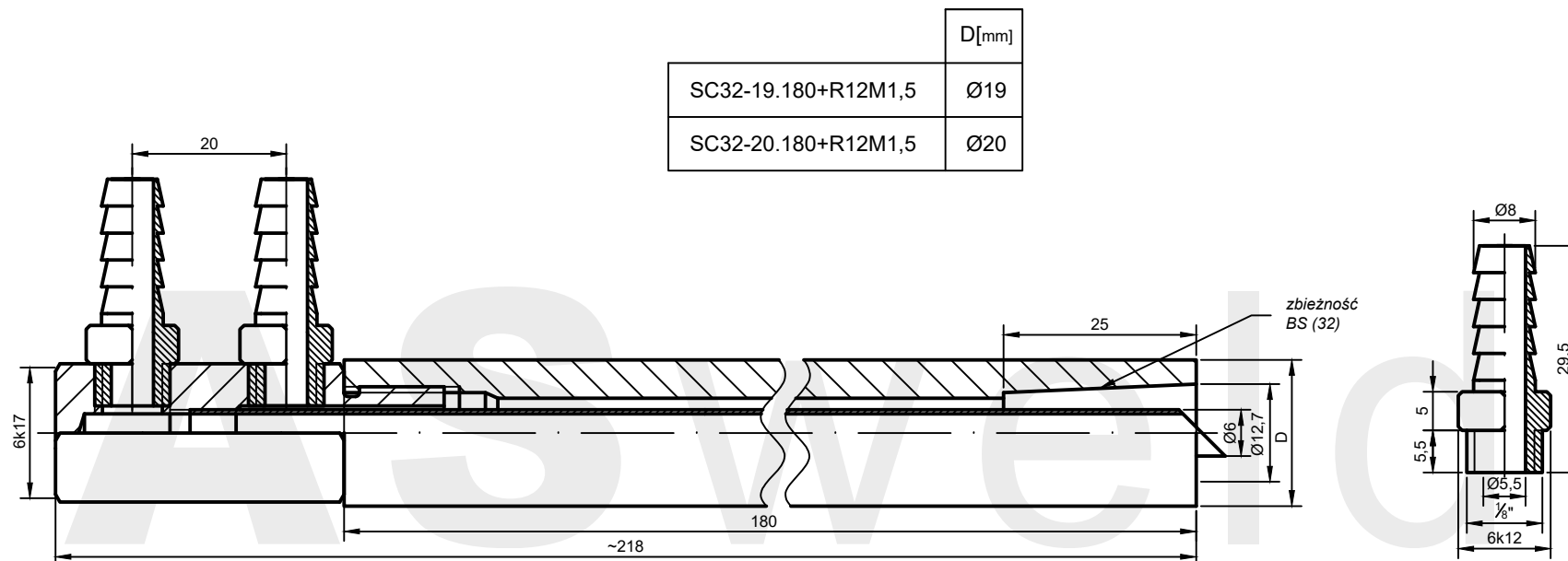

AW: SC32-D.180+R12M1,5

*wykonanie na zamówienie

ASweld

ŚWIECA Z ROZDZIELACZEM

Mocowanie

32

Karta katalogowa

10-02-01-32

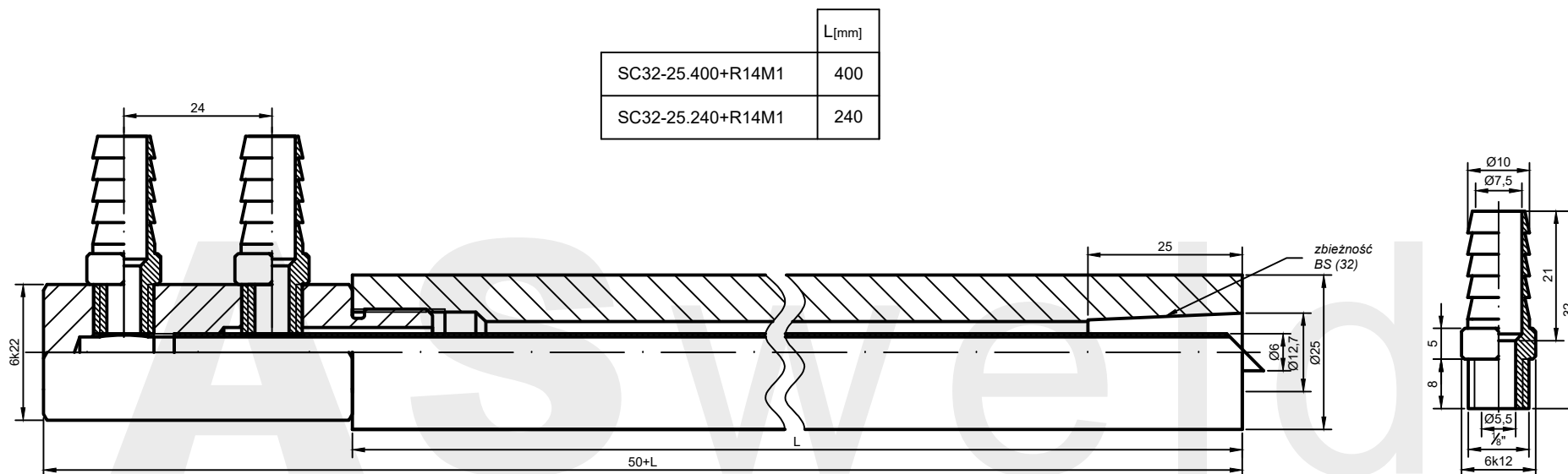

AW: SC32-25.L+R14M1

*wykonanie na zamówienie

ASweld

ŚWIECA Z ROZDZIELACZEM

Mocowanie

32

Karta katalogowa

10-02-02-32

ASweld

ELEKTRODY KRAŻKOWE

Karty katalogowe: 11-__-__-__



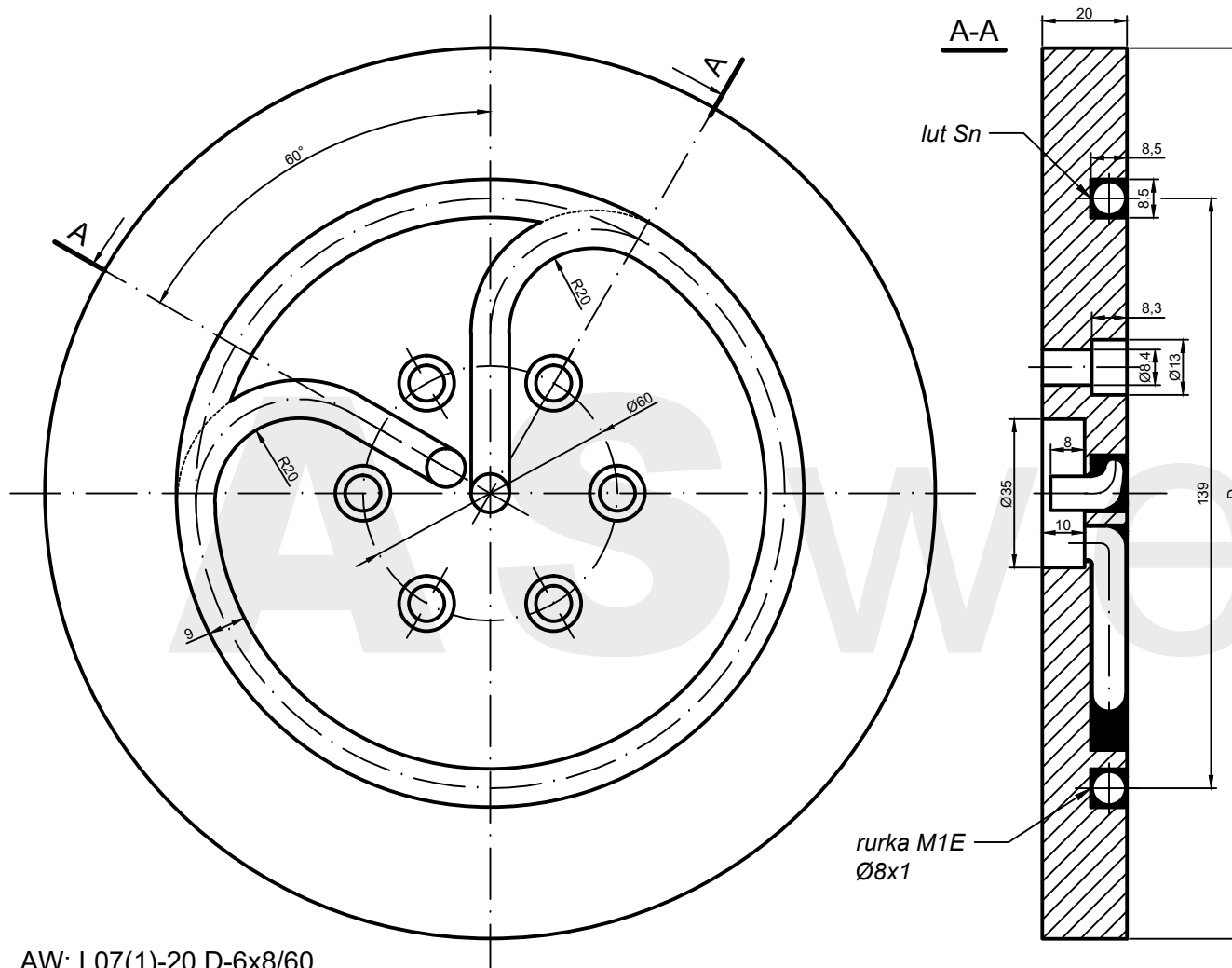

Elektroda	Typ ostrzenia	D
L07(1)-20.210-6x8/60*	1	210
L07(1)-20.240-6x8/60*	1	240
L07(2)-20.210-6x8/60*	2	210
L07(2)-20.240-6x8/60*	2	240
L07(3)-20.210-6x8/60*	3	210
L07(3)-20.240-6x8/60*	3	240
L07(4)-20.220-6x8/60*	4	220
L07(4)-20.240-6x8/60*	4	240

Typy ostrzenia

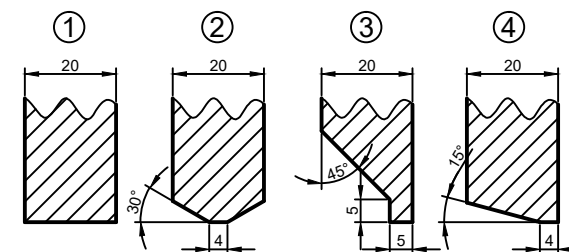

*wykonanie na zamówienie

AW: L07(1)-20.D-6x8/60

ASweld

**ELEKTRODA KRAŻKOWA
Z CHŁODZENIEM BEZPOŚREDNIM**

Mocowanie

6x8/60

Karta katalogowa

11-01-01-6x8/60

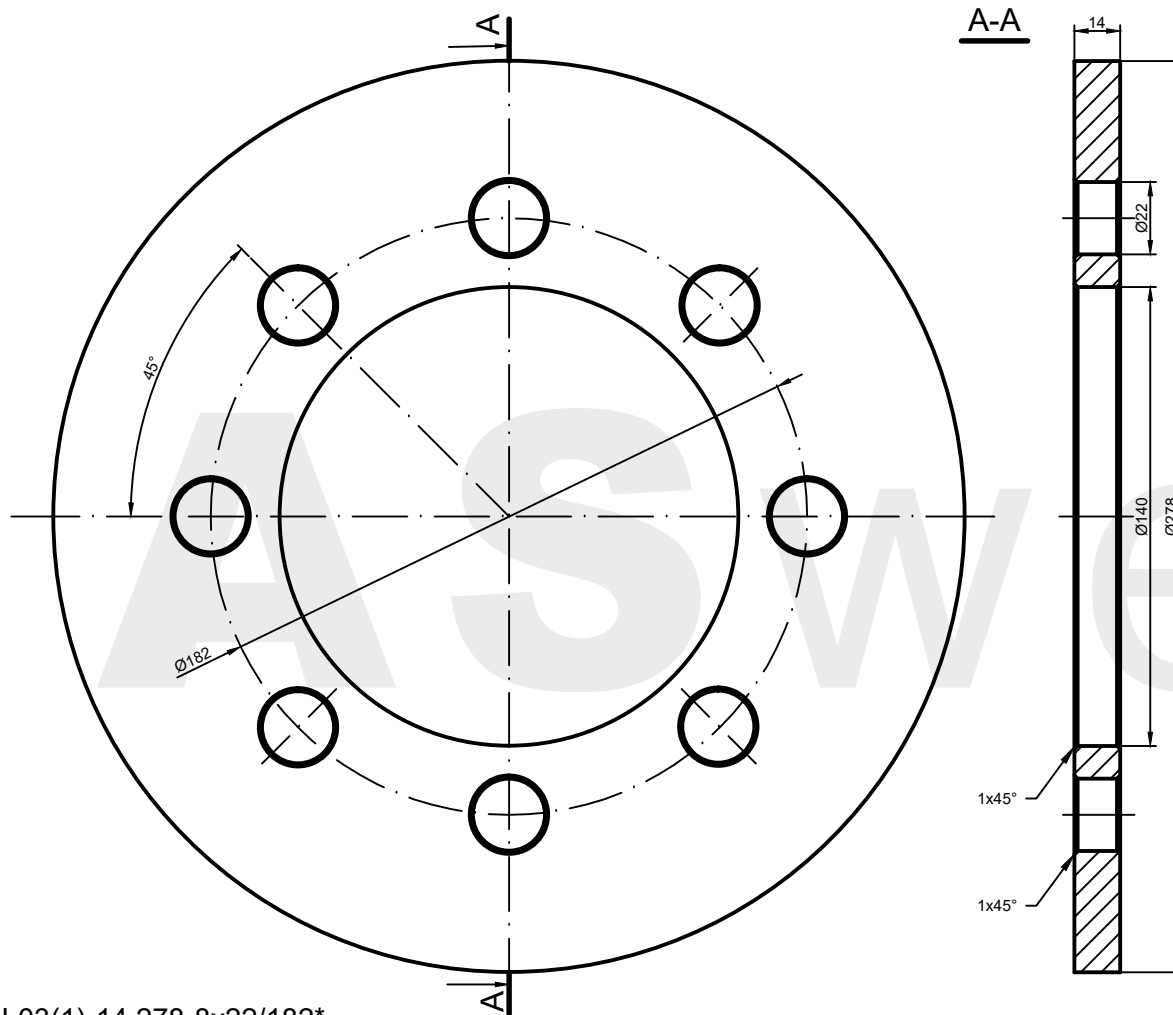

Elektroda	Typ ostrzenia
L03(1)-14.278-8x22/182*	1
L03(2)-14.278-8x22/182*	2
L03(3)-14.278-8x22/182*	3

Typy ostrzenia

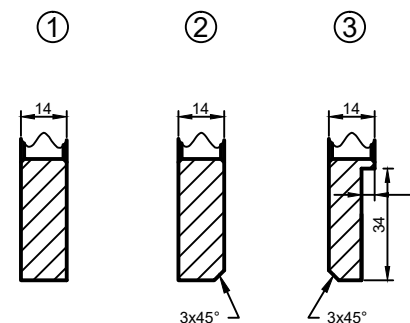

*wykonanie na zamówienie

AW: L03(1)-14.278-8x22/182*

ASweld

ELEKTRODA KRAŻKOWA

Mocowanie

8x22/182

Karta katalogowa

11-01-02-8x22/182

Biuro:

NIP: 898-117-63-97
ul. Grunwaldzka 22
50-355 Wrocław
Tel: 600 469 939
e-mail: krzysztof.wojtal@asweld.pl

Produkcja elektrod:

Ul. Jana Długosza 2-6, Budynek 7
51-162 Wrocław
Tel: 530 718 577
e-mail: elektrody@asweld.pl

